

WARRANTY

Intek, Inc. warrants each *Rheotherm* product to be free from defects in material and workmanship under normal use and service, Intek's obligation under this warranty being limited to making good any part or parts thereof which shall, within one (1) year after delivery of such product to the original purchaser, be returned to Intek with transportation charges prepaid and which Intek's examination shall disclose to its satisfaction to have been thus defective; this warranty being expressly in lieu of all other warranties, express or implied and all other obligation or liabilities on Intek's part. The purchaser will assume all responsibility and expense for removal, decontamination and reinstallation of equipment.

Rheotherm flow meters are manufactured under United States patent numbers 4,255,968, 4,942,763 and 4,949,578. Intek, *Rheotherm*, Rheovec, *RheoVac*, RheoSmart and Rheomax are registered trademarks of Intek, Inc.

Intek, Inc.
751 Intek Way
Westerville, Ohio 43082-9057
TEL: (614) 895-0301 • FAX: (614) 895-0319
E-mail: techsupport@intekflow.com

TABLE OF CONTENTS

SECTION 1 – GENERAL INFORMATION	- 1 -
1.1 INTRODUCTION	- 1 -
1.2 DESCRIPTION OF OPERATION	- 2 -
1.3 PRECAUTIONS	- 2 -
SECTION 2 – INSTALLATION	- 4 -
2.1 TRANSDUCER	- 4 -
2.2 ELECTRONICS	- 6 -
2.3 ELECTRICAL CONNECTIONS	- 6 -
SECTION 3 – OPERATION	- 8 -
3.1 START UP	- 8 -
3.2 FIELD ADJUSTMENT INSTRUCTIONS	- 8 -
TABLE I. Alarm1 Output Configuration	- 9 -
TABLE II. Alarm2 Output Configuration	- 10 -
3.3 GENERAL INFORMATION	- 10 -
3.4 OUTPUT CURVE	- 11 -
SECTION 4 – MAINTENANCE	- 12 -
4.1 GENERAL MAINTENANCE	- 12 -
4.2 FIELD CALIBRATION	- 12 -
4.3 SPARE PARTS	- 13 -
4.4 TROUBLE SHOOTING	- 13 -
TABLE III. TROUBLE SHOOTING GUIDE	- 13 -
SECTION 5 – CUSTOMER SERVICE	- 14 -
5.1 QUESTION ON EXISTING HARDWARE	- 14 -
5.2 TROUBLE SHOOTING	- 14 -
5.3 FACTORY AND FIELD SERVICE	- 14 -
5.4 DECONTAMINATION OF EQUIPMENT	- 14 -
5.5 QUESTIONS ON NEW EQUIPMENT	- 14 -
SECTION 6 – CUSTOM INFORMATION	- 15 -
6.1 UNIT IDENTIFICATION	- 15 -
6.2 CONFIGURATION	- 15 -
6.3 SPECIAL INSTRUCTIONS	- 15 -
DRAWING 94080-5. Model 400 Flow Switch Field Wiring Interface	- 16 -

SECTION 1 – GENERAL INFORMATION

1.1 INTRODUCTION

Rheotherm[®] flow monitors and flow switches offer reliable flow detection in liquids, gases and slurries. They are manufactured exclusively by Intek, Inc. and employ a patented thermal technique used by industry since 1978. The unique transducer designs have protected sensors, are easy to install and require little or no maintenance.

Each *Rheotherm* flow meter consists of two elements — a transducer and an electronics unit. The transducers come in two basic designs, intrusive and nonintrusive (SECTION 2.1). Design selection is based on application constraints or customer preference. The Model 400 electronics, for signal processing, are housed in an explosion-proof enclosure which is integrally mounted on the transducer.

The Model 400 flow switch/monitor is designed to be used for flow rate monitoring and trending, flow / no flow detection, or specific low and/or high level alarm(s) over a nominal 10 to 1 flow range. These units can also be used to detect the presence or absence of liquid in a line. The Model 400 can be ordered equipped with one SPDT relay and one 4-20mA nonlinear flow monitor output, or equipped with two adjustable SPDT relay switches and no flow monitor output.

Key features of the Model 400 *Rheotherm* flow switches / flow monitors are:

- No moving parts — There are no rotating, translating, undulating or oscillating parts to wear, stick, break or fatigue.
- Ruggedness/chemical compatibility — The wetted surface(s) can be any of a number of corrosion resistant metals or alloys. There are no internal joints or seals in a TU or TUL type transducer. The standard material of construction for the transducers is 316 stainless steel.
- Immunity to shock and vibration.
- Adjustable set point(s) with red/green bicolor LED.
- 4-20mA flow output for flow monitoring, trending or data logging.
- User selectable time response enhancement feature.
- Fluid pressure options to 5,000 psi.

The Model 400 flow switch/monitor is designed for moderate temperature applications. Intek, Inc. also manufactures flow switches and precision linear flow meters to meet more demanding process environments. *Rheotherm* instruments have proven performance in a wide variety of demanding liquid and gas flow applications, including:

- Low liquid flows from a few GPM down to 20 cc/day.
- True mass flow in large diameter air/gas ducts.
- Low liquid velocities in large lines (down to 0.5 ft/min).
- Vacuum system air in-leak monitoring in power plants and other vacuum drying processes.

1.2 DESCRIPTION OF OPERATION

Rheotherm flow instruments are available with various nonintrusive and intrusive transducer designs, but they all use the same thermal sensing technique. Two temperature sensors are used — one is in thermal equilibrium with the fluid and provides a fluid temperature reference, while the second temperature sensor is located near a heater so that its temperature is slightly above that of the fluid. In a TU or TUL transducer, the temperature sensors and heater are attached to the outside of the flow tube, whereas the dual and single probe transducers have the sensors and heater located in the probe(s) that are inserted into the stream. The amount of heat removed from the heated sensor by the stream is related to fluid velocity. Hence, the measured temperature differential between the reference sensor and heated sensor is a function of flow rate. Intek, Inc. is licensed to use this patented and trademarked flow measurement technique. The Model 400 electronics converts this temperature difference and a portion of the fluid temperature signal into a temperature compensated and scaled flow output signal. The signal, for most cases, is proportional to the logarithm of flow rate. Intek also utilizes a proprietary electronic time constant enhancement technique. When enabled, this feature decreases the time required to detect the loss of flow by as much as a factor of ten (10).

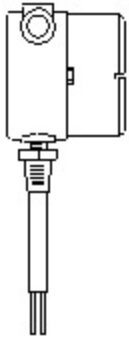

Example of
dual probe
NPT/2I



Example of
single probe
NPT/I

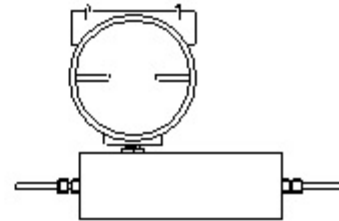

94080-07

Example of
nonintrusive transducer
(TU-style)

1.3 PRECAUTIONS

1. Use proper input power — Check the label on the electronics for the input power requirements.
2. Use reasonable care in handling the transducer. Do not try to disassemble the transducers; there are no removable parts.

Probes (NPT/2I, NPT/I, BF/2I, BF/I, etc.) — take care not to bend the probes or damage the tips. Do not try to remove or turn the conduit junction box.

TU or TUL — twisting or bending can damage the sensor. The flow tubes are thin-walled tubing.

3. Check the transducer maximum temperature rating — do not operate a transducer at or subject it to a temperature outside of its specified limit(s).
4. Keep moisture out of the electronic enclosure and sensor junction box. Once cable connections are made in the junction box, make sure the lid is tightly closed. Seal conduit lines if they can become wet inside.

5. Keep transducer wetted surfaces clean and free of permanent layer build-up. A layer build-up can cause the sensor to read less than the actual flow rate and can cause false relay trips.
6. Do not exceed pressure limits of the tube or fittings.
7. Maintain a thermally stable environment (short-term) for the transducer and adjacent line. (See SECTION 2 — INSTALLATION.) Large fluid temperature transients can result in false alarms. Consult factory for recommendations to minimize the impact of thermal transients.

These instructions cover installation, calibration and maintenance of *Rheotherm* meters in standard configurations. Any special information pertaining to your unit is covered under CUSTOM INFORMATION (SECTION 6). Time should be taken to carefully read these instructions prior to installation of the equipment. Should any questions arise or problems occur, call Intek for immediate assistance.

SECTION 2 – INSTALLATION

2.1 TRANSDUCER

!! IMPORTANT: All transducers have a directional arrow on the tag and/or etched into a metal part. Before installing a sensor, please note proper flow direction. This is critical to sensor operation.

!! IMPORTANT: If you have more than one *Rheotherm* unit, make sure the complete serial number of the transducer matches the complete serial number of the electronics module. The transducer and electronics are a matched set. Components with different serial numbers cannot be interchanged. The transducers have no user serviceable parts, so do not try to disassemble, as permanent damage may result.

The transducer style supplied with your meter is listed in the model code number in SECTION 6. Proper installation of the sensor is necessary for achieving accuracy and repeatability. Installation suggestions for each type of standard transducer are given here. For custom transducer installations, refer to CUSTOM INFORMATION — SECTION 6.

Be sure wetted surfaces are clean before installing. If cleaning is needed, use non-residue solvent and wipe dry. If the sensor has a connector box, keep moisture out. Make sure the lid is tightly sealed and, if supplied, the gasket is in place. Seal conduit lines at the connector box if conduit lines can become wet.

1. Intrusive Probes —

!! IMPORTANT: Recommended straight run for best accuracy is 20 diameters upstream and 10 diameters downstream.

Probe type flow switch/monitors should be handled with sufficient care so as not to bend or otherwise damage the probes. Ensure that the temperature and pressure limits of the instrument are compatible with your application. Be sure wetted surfaces are clean before installing. If cleaning is needed, use a non-residue solvent and wipe dry. The instrument should be mounted through the pipe wall using a thread-o-let, flange fitting or hot-tap, with the standard being a 1" NPT. Check to ensure that the probes are long enough to be well immersed in the flowing fluid. Generally, the probes are sized so the tips extend $\frac{1}{4}$ to 1 inch beyond the pipe center line when properly installed. There are exceptions to this in certain applications; see CUSTOM INFORMATION (SECTION 6) as it applies.

Proper alignment of the sensor with flow is important; the flow direction is indicated on the

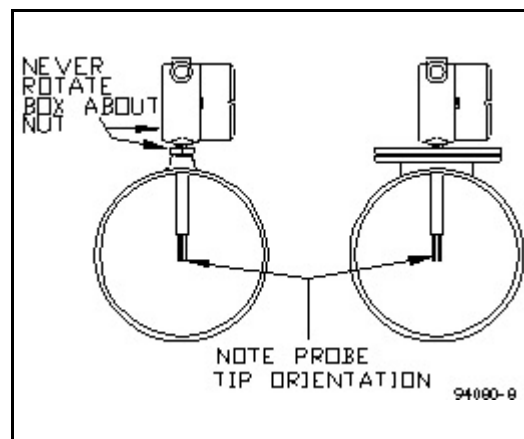

Figure 1. Intrusive Probe Installation.

transducer tag and/or etched into the transducer. All dual probe transducers (NPT/2I, BF/2I) are installed so that the two probes are side-by-side across the fluid stream. Never rotate the electronics housing. If this occurs the transducer can be damaged and/or installed misaligned with the flow direction.

The probe transducer units, particularly when they are used as flow monitors, will give the most accurate results with a straight run of pipe upstream and down stream of the probe. Straight run length of 20 diameters upstream and 10 diameters downstream is recommended.

2. TU or TUL (nonintrusive) — TU or TUL transducers particularly require special care in handling and installing to avoid damage to sensor tube stubs.

!! CAUTION: TU and TUL transducers are made with thin-walled tubing — use care when installing.

All TU and TUL transducers should have straight line input and output sections, typically 20 pipe diameters on the inlet and 6 to 10 diameters on the outlet. If installed vertically, the flow should be going up through the sensor. Connection in the line is via compression fittings, hose with clamp, threaded fittings or flanges, whichever is appropriate. Care must be taken not to transmit a twisting force through the transducer's midsection. The TU or TUL transducer, whether flanged or not, must not be used to pull other piping together or to make up angular mismatch of fittings. The integral electronics box should never be rotated for any reason.

Flow stream conditioning must also be considered to maximize meter performance. Avoid upstream protrusions and short distance straight runs. Flow pulsations, such as those created by metering pumps, may cause the instrument to differ from the factory calibration. Furthermore, if the flow is varied by stroke and by pump speed adjustment, the indication will most likely be non-repeatable. If you are using a pump of this type, it is recommended that a pulsation dampening device be used to provide smooth continuous flow. A second choice would require readjustment of the instrument calibration (cal) potentiometer after installation (See SECTION 4.2).

For liquid measurement systems using high pressure gas to force flow, the effects of the absorbed gas must be considered. In these cases, sudden pressure drops upstream of the sensor such as line size expansions, control valves, and pressure dropping regulators must be avoided. Sudden pressure drops can cause the absorbed gas to release into the liquid, making the flow sporadic and difficult to measure. Control valves should be placed down stream of the sensor.

Fluid temperatures other than ambient require special attention. Thermal gradients from one end of the transducer to the other (for TU and TUL transducers), as well as along the radius of the connection pipe, are undesirable. Therefore, effective insulation should be installed around the inlet and outlet straight line runs. Gradients which may exist in the line further up stream can be removed if an insulated elbow is installed in the line prior to entering the straight line portion of the plumbing. Metallic support braces for the sensor or adjoining plumbing can act as a heat sink and cause operational problems in high temperature applications. The support braces should be thermally isolated from the line to avoid large heat conduction effects.

If the transducer is for use above 75°C, it will have an extension arm between the transducer and the electronics module enclosure. Free air should be allowed to flow around the extension arm and electronics enclosure to keep the electronics cool. The extension arm can be insulated up to one-third of its length from the transducer body. Proper thermal control is vital to accurate meter performance. Non-uniform heat tracing, relay on/off temperature controllers and oscillating proportional type control should always be avoided. Steam traced lines with good pressure regulation or properly tuned proportional temperature control systems are

effective in maintaining uniform fluid temperature. The ideal installation will provide the sensor with well established smooth flow, uniform system temperature and consistent fluid media.

2.2 ELECTRONICS

The standard enclosure for the integral electronics is an explosion-proof cast junction box.

!! CAUTION: The electronics are not protected against condensing liquid water inside the enclosure. If conduit is used, be sure conduit is dry or sealed at the instrument to prevent conduit condensation from entering the electronics enclosure.

Unless otherwise specified, normal ambient environment for the electronics is 40-120°F. Recommended maximum temperature is 135°F.

2.3 ELECTRICAL CONNECTIONS

1. Power — The input power requirement is listed on the tag on the electronics enclosure; make sure the input power source is compatible. Available input power configurations are 24 Vdc, 24 Vac, 115 Vac, or 230 Vac. The Vac power is ½A, 50-60 Hz, single phase. The power configuration is pre-set at the factory, but may be changed in the field (except for 115 to 230 Vac conversions). To select either 24 Vac or high voltage (115 or 230 Vac), ensure that power has been disconnected. Then, remove the electronics module by removing the modular sensor interface connector and then by pulling the handle on the top printed wiring board (PWB). Using **Figure 2**, locate the power select jumper on the lower PWB and simply move the power select jumper to either the “Lo” (24 Vdc or 24 Vac) or “Hi” (115 Vac or 230 Vac) position. Do not apply power until the power select jumper position is visually verified.

Wire size no smaller than 24 gauge can be used for power. Fourteen (14) gauge stranded wire is recommended for the relay contacts. The input power, analog output (for models with that option), and relay connections are made as shown by Drawing 94080-5 in the back of this manual. Note the electronics module is removable for easy termination of the wires. **DO NOT** attempt to install wiring with the electronics module in place within the enclosure. Bend and cut the wires for a low profile fit, being careful not to stress them. Ground the enclosure with a separate wire. Once all connections are made, firmly push the module back into its base noting the position of the keying post. The electronics signal ground is isolated from the

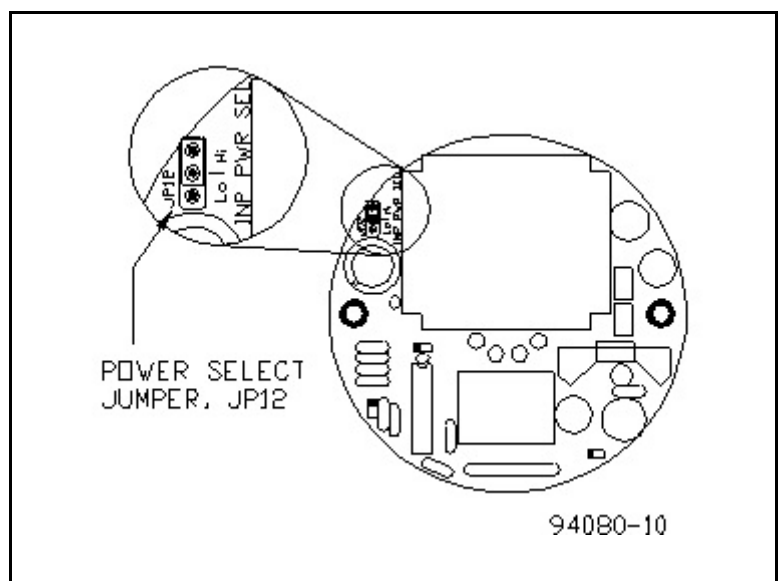

Figure 2. Input Power Selection Jumper Location

transducer casing and therefore the analog output is isolated from earth ground. However, if the power select jumper is set in the “Lo” position, the analog output will not be isolated from the incoming power line.

Install conduit such that all seals are watertight and rigidly secure. After pulling wire, pot the conduit near the enclosure if there is any possibility of them trapping water or moisture. The lid of the enclosure should be on tight enough to make a good seal against the gasket. Ensure all enclosure openings are completely watertight.

As a general rule, if the flow is to be shut off or the flow line empty for long periods of time, power to the unit should also be turned off. An on/off switch, provided by the customer, is recommended for all industrial installations.

SECTION 3 – OPERATION

3.1 START UP

Typically, the instruments come from the factory set up for a 10 to 1 flow rate span, with the trip level set approximately at 10% of the full scale value. SECTION 6 details the instrument specifications. Following installation all that is required is to switch on power and initiate flow in the measurable flow rate range. The following figures and tables show how to configure the Model 400 alarm setpoint(s), high/low alarming, and time response. Liquid meters that are not calibrated directly on the liquid to be measured are so indicated in this manual (SECTION 6) and require an in-line field calibration.

When power is first turned on, the output reading or signal will indicate full scale. After ten to forty-five seconds (depending on flow range adjustment) the reading will stabilize. The instrument time constant is generally between 4 to 12 seconds. Higher average flow rates will result in an observed faster response time for a given unit.

3.2 FIELD ADJUSTMENT INSTRUCTIONS

The flow switch/monitor may initially indicate a high flow rate even for zero flow when power is first applied to the unit. Correct indication of flow or level will result after an initial period which can extend to about forty seconds depending on where the level adjust is set. Apply power only after reading and adhering to instructions in SECTION 2 of this manual.

3.2.1 Adjustment of the ALARM1 flow switch setpoint (all Model 400 types)

- A. Establish a flow rate at the desired trip level. This should be done with flow in the line, not at zero flow. Set the alarm switch, S1, to “**LO**” if alarming at a rate below this flow value is desired; set it to “**HI**” if alarming at a rate above this flow value is desired. An example would be to use 50% of your lowest normal flow rate as the set point and setting S1 to “**LO**.”
- B. If the LED is *green*, adjust “**Trip 1**” potentiometer clockwise* until the relay de-energizes (LED turns *red*). This is the alarm condition.
- C. If the LED is *red*, adjust “**Trip 1**” potentiometer slowly counter clockwise* until the relay energizes (LED turns *green*).
- D. If the relay cannot be made to drop out over the full range of the “**Trip 1**” potentiometer, see Table III.

*Reverse direction of turns if S1 is set to “**HI**” position.

3.2.2 Adjustment of the ALARM2 flow trip setpoint (when S2 option is ordered)

The ALARM2 flow switch is energized at flows below the trip level and does not have an LED to indicate alarm state. The relay contacts must be monitored to determine the relay state (refer to Table II). If one relay is to be used for high flow alarm and one relay for low flow alarm, RELAY1 should be used as the “lo” alarm and RELAY2 used as the “hi” alarm.

- A. Establish a flow rate at the desired trip point. The relay in standard flow switches is picked up (energized) when the flow level is above a set point. A low level is therefore indicated in the event of loss of power to the sensor when connected to N.C. contacts. Relay 2 will be energized with flow below the trip level.
- B. If RELAY2 is energized, adjust “**Trip2**” potentiometer counter clockwise until the relay de-energizes. This is the alarm condition.
- C. If RELAY2 is de-energized, adjust “**Trip2**” slowly clockwise just until the relay energizes.
- D. If the relay cannot be made to drop out over the full range of the “Trip2” potentiometer, see Table III.

TABLE I. Alarm1 Output Configuration (all Model 400 units)

S1 Position	NC1 - COM contacts	Relay1 State	LED1 Status	Flow Rate	Liquid Level
LO	Open	energized	Green	Above set point	Liquid
LO	Closed	de-energized	Red	Below set point	Air
HI	Closed	de-energized	Red	Above set point	Liquid
HI	Open	energized	Green	Below set point	Air

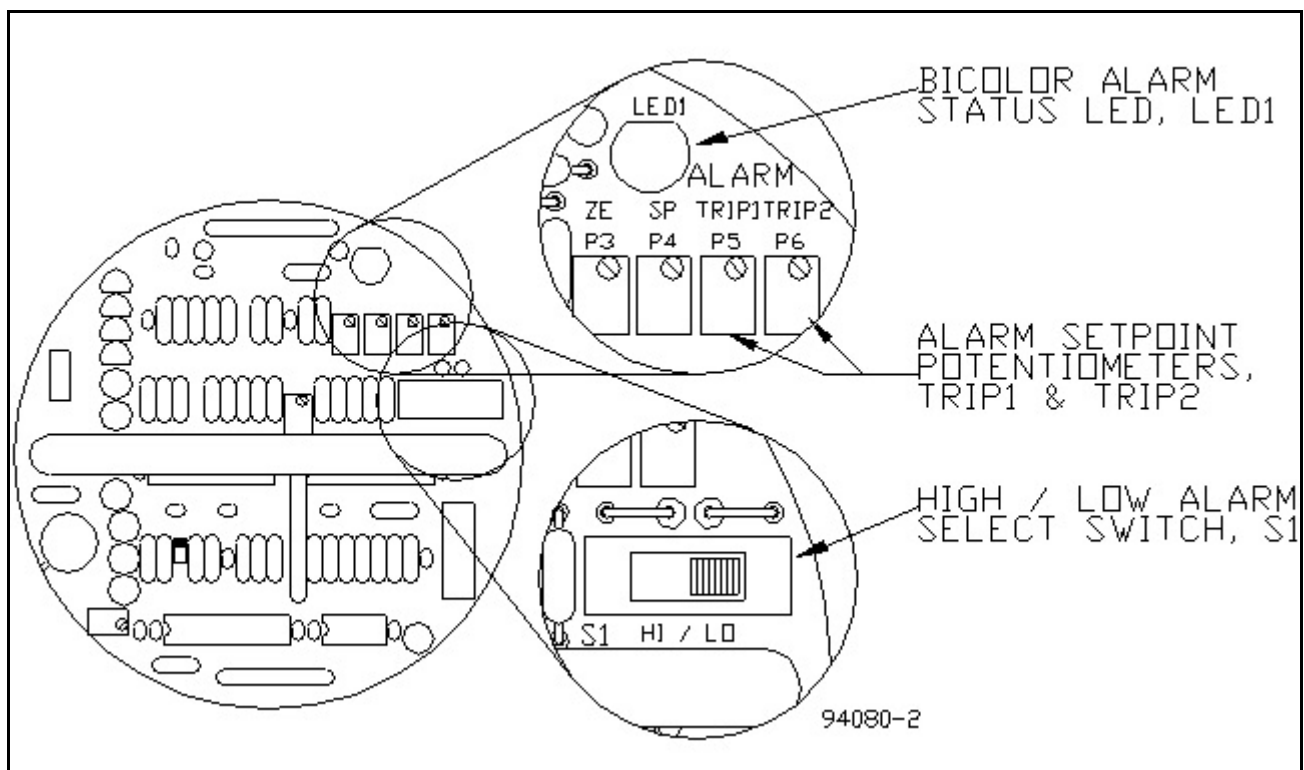

Figure 3. Set point Adjustment Components and Locations

TABLE II. Alarm2 Output Configuration (units with S2 option)

S1 Position	NC2 - COM contacts	Relay2 State	LED1	Flow Rate	Liquid Level
N/A	Closed	de-energized	N/A	Above set point	Liquid
N/A	Open	energized	N/A	Below set point	Air

The response time of the Model 400 can be changed between two settings: “**Slow**” and “**Fast.**” This change is made by moving the jumper shunt at JP7 (see Figure 4). The unit will usually come from the factory set in the “**Slow**” position. Notice that in the “**Slow**” position, the response is sluggish but noise-free. The fast response position will cause any alarming to be accelerated, however, it will allow flow noise to be present in the instrument’s output signal.

In general, when the output signal is being monitored, the “**Slow**” position is best. When the unit is used strictly as a flow switch, it may be useful to use the “**Fast**” setting for gas flow or level monitoring systems, and the “**Slow**” position for high velocity liquid flow systems. Figure 5 shows typical response differences between the two settings.

3.3 GENERAL INFORMATION

The Model 400 instrument is compensated for a wide range of both ambient and flowing media temperatures. However, abrupt changes in the temperature of the flowing material can cause the instrument output to deviate from the true representation of flow rate, which in turn could lead to an inappropriate tripping of the relay or a delay in reading a loss of flow. A proper reading is obtained only when the transducer is in thermal equilibrium with the material. Typically, a 20°F abrupt change in temperature may require 40 seconds to stabilize. Temperature ramps should be kept below 1°C/minute.

In general, the heater used in the transducer does not develop enough power to cause damage to the system in the absence of flow. This includes those used in liquids even if the line becomes empty and is filled with air. *Rheotherm* instruments have additional circuitry which prevents overheating in the event of the loss of flow. This thoroughly protects the instrument from damaging itself. Although it is not required, it is recommended that the instrument power be shut off when the instrument is not in use. Any special cases concerning unique requirements may be discussed in SECTION 6,

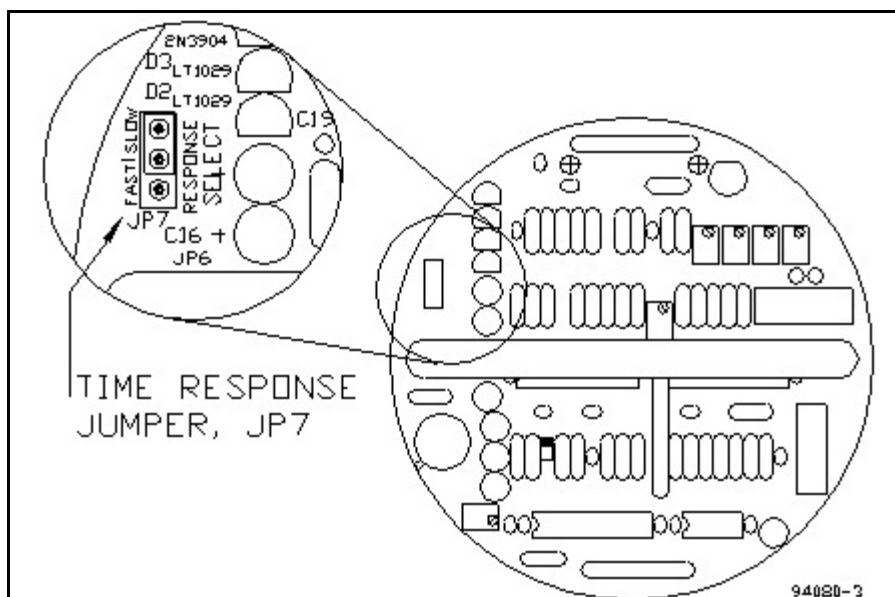

Figure 4. Time Response Selection Jumper Location

CUSTOM INFORMATION.

3.4 OUTPUT CURVE

If the instrument is ordered with a calibrated output signal, the output curve for the unit can be found after SECTION 6. For an uncalibrated unit with a 4-20mA option, a typical curve is shown in Figure 6. Check SECTION 6 for the corresponding full scale value for this instrument. Flow can also be found by the formula:

$$\text{FLOW (\%FS)} = \exp [\exp (0.5547 * X + 0.26935)] / 0.1758$$

where X is the flow output signal in mA.

TYPICAL OUTPUT CURVE

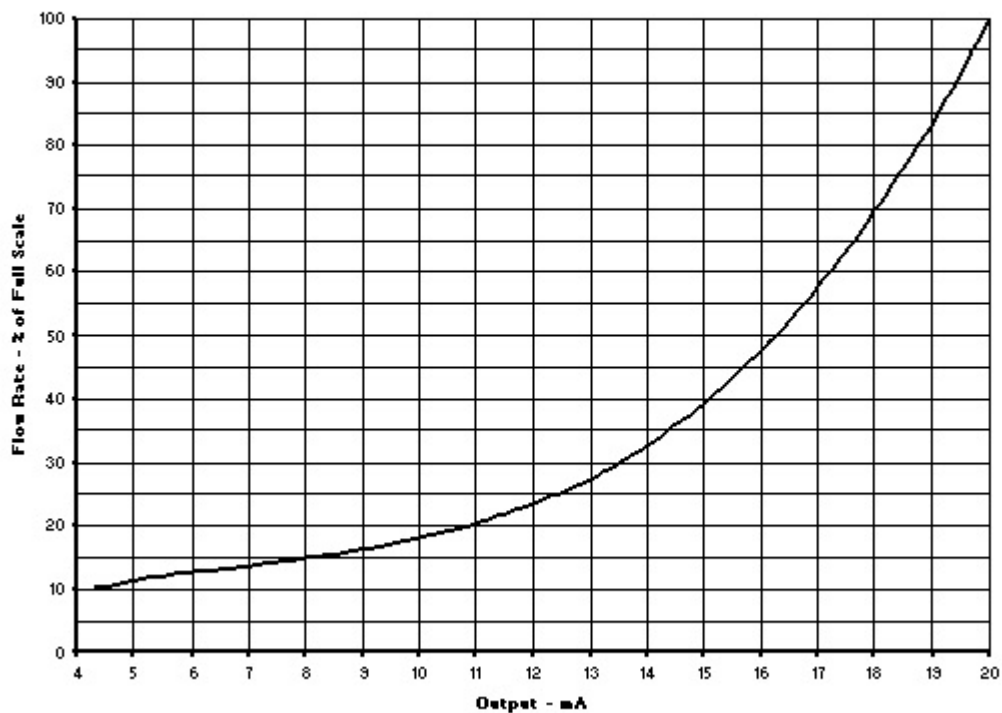

Figure 6. Typical Output Curve (for units with 4-20mA output option)

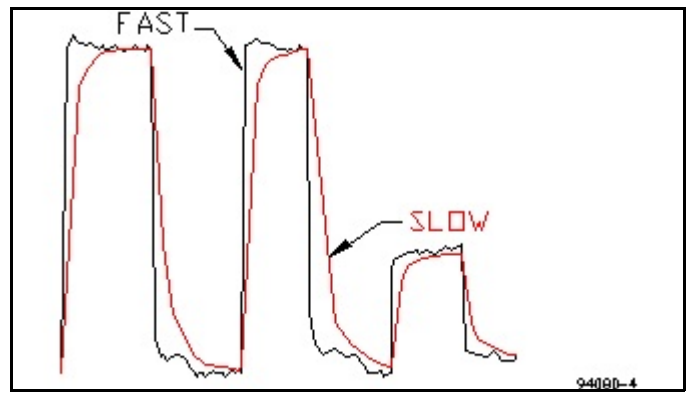

Figure 5. Typical Time Response Characteristics

SECTION 4 – MAINTENANCE

4.1 GENERAL MAINTENANCE

Certain precautions should be taken to insure proper performance of all models of flow instruments. Since the measurement technique involves a signal resulting from heat transfer to the flowing medium, care should be exercised to prevent build-up of varying layers on the walls of the transducer. Layers such as bacterial growth, dried paints, gas bubbles and non-solubles can result in measurement below actual flow rates. Periodic checks and cleaning should be performed to insure a clean pipe or probe surface.

It should be part of normal maintenance procedure to check the system for proper functioning. Experience and other observable conditions should be utilized to determine the frequency of inspection. To test the flow switch action, the flow rate should be reduced below (for low flow switch) or raised above (for high flow switch) the switching level. When the unit reaches alarm mode (de-energized relay, LED is *red*), check and insure relay action and continuity of the shut down or warning circuits which it operates.

The joints of all intrusive probes tips should be inspected for wear and corrosion.

4.2 FIELD CALIBRATION

If the unit was purchased with a 4-20mA output, and calibrated at the factory or by the customer, a field recalibration can be performed as follows:

1. Establish a known flow rate near 10-15% of the desired full scale value. Monitor the flow output for stability.
2. Locate the zero potentiometer (pot) labeled P3 using Figure 3. Identify the proper flow output signal corresponding to the current flow rate (see Figure 6 or the supplied calibration curve, as applicable). After the flow has stabilized, adjust P3 until the flow output agrees with the desired output value.
3. Establish a known flow rate near 95-100% of the desired full scale. Monitor the flow output for stability.
4. Locate the span pot labeled P4 using Figure 3. Identify the proper flow output signal corresponding to the current flow rate (see Figure 6 or the supplied calibration curve, as applicable). After the flow has stabilized, adjust P4 until the flow output agrees with the desired output value.
5. Since potentiometers P3 and P4 are slightly affected by the adjustment of the other, repeat steps 1 through 4 until the desired accuracy level is achieved.

6. In general, the curve shapes do not change if the zero and span values are set properly. If the instrument is being re-ranged, simply use a new full scale value and normalize the output curve to 100%. If extreme nonlinearities exist, such as that of a laminar to turbulent flow regime transition, a new curve will need to be constructed. Furthermore, if a transition region exists and the instrument must operate over a range of temperatures, several curves must be constructed at fixed temperature steps throughout the temperature range to assure best accuracy.

4.3 SPARE PARTS

There are no normally recommended spare parts to stock. The transducer and electronics boards are a matched set and therefore are not interchangeable with others. Should a spare be needed, a complete unit should be ordered and stocked. Spare fuses are ½A fast acting Wickmann fuse, part number 3730500041 or equivalent for 115/230 Vac usage and 1A slow blow Wickmann fuse part number 3741100041 for 24V usage.

4.4 TROUBLE SHOOTING

TABLE III. TROUBLE SHOOTING GUIDE

OBSERVATION	PROBABLE CAUSE	REMEDY
Flow trip level continually drifting downward with constant flow.	Coating forming on wetted surface of transducer.	<ol style="list-style-type: none"> 1. Clean transducer periodically. 2. Adjust span potentiometer clockwise until layer build-up stabilizes.
After flow switch has been operating properly: Relay incorrectly trips with flow above or below trip level and cannot be adjusted using instructions in SECTION 3.2.	<ol style="list-style-type: none"> 1. Dirty electrical contacts. 2. Bad electronic component 	<ol style="list-style-type: none"> 1. Inspect electronics module and its socket for corrosion. Clean and replace. 2. Contact factory.
Relay cannot be made to trip by adjusting trip adjustment potentiometer(s).	<ol style="list-style-type: none"> 1. Flow rate out of range of instrument. 2. Flow media change. 	<ol style="list-style-type: none"> 1. Refer to SECTION 4.2 on calibration to re-range the instrument. 2. Contact factory.
Relay trips on and off, or flow signal is very noisy but flow is constant and steady.	<ol style="list-style-type: none"> 1. Flow noise is being amplified by fast response circuitry. 2. Instrument has been readjusted or instrument is defective. 	<ol style="list-style-type: none"> 1. Move time response jumper to "SLOW." 2. Contact factory.
LED is not lit and relay stays in alarm condition (N.C. contact is made).	<ol style="list-style-type: none"> 1. No power to electronics. 2. Blown fuse. 	<ol style="list-style-type: none"> 1. Check incoming voltage. 2. Replace fuse with appropriate ampere and time delay rating. 3. Return to factory.

SECTION 5 – CUSTOMER SERVICE

Intek's corporate philosophy is to solve our customer's difficult flow measurement/monitoring problems. This means that each instrument is custom configured and calibrated for the application. When you purchase a *Rheotherm* instrument you also receive Intek's outstanding customer service. For sales or product service, call your local representative or Intek directly at (614) 895-0301 8AM to 5PM EST/EDT weekdays or fax us anytime at (614) 895-0319. Our customer service staff will provide assistance promptly. Our website at www.intekflow.com is available for additional information; for submitting questions or comments, you may also e-mail to www.techsupport@intekflow.com.

5.1 QUESTION ON EXISTING HARDWARE

To allow us to help you more quickly, please have the serial number of the equipment available before you call. If your company is not the original purchaser the identity of the original recipient will also be helpful.

5.2 TROUBLE SHOOTING

If you have reviewed SECTION 4.3 TROUBLE SHOOTING and have questions, please call our experienced engineers for assistance. In many cases we can solve a problem over the phone. Please provide as complete a description as possible of the problems encountered.

5.3 FACTORY AND FIELD SERVICE

Model 400 flow switch/monitor cannot be serviced in the field. If a problem cannot be solved through a telephone conversation with one of our engineers, the unit should be returned to the factory for inspection.

To request factory service, a Return Material Authorization (RMA) and purchase order is required. Our customer service staff will assist you with the required information to return instruments for service.

5.4 DECONTAMINATION OF EQUIPMENT

For the safety of your personnel and ours, any hardware that has been in contact with potentially hazardous liquids or gases must be properly decontaminated before shipment to Intek.

5.5 QUESTIONS ON NEW EQUIPMENT

For a new *Rheotherm* application or any liquid or gas flow measurement need, visit us at our website, www.intekflow.com or contact your local *Rheotherm* representative or the Intek technical sales department at the above phone/fax numbers. Our staff will be pleased to answer all questions and provide quotations.

SECTION 6 – CUSTOM INFORMATION

6.1 UNIT IDENTIFICATION

Model no.: _____

Serial no.: _____

Customer identification: _____

6.2 CONFIGURATION

The configuration of this unit, as originally shipped from the factory:

Input Power:

- 20-28 Vdc 20-28 Vac
 100-130 Vac, 50/60 Hz 200-240 Vac, 50 Hz other _____

Maximum Pressure:

Full Scale Flow:

Analog Output:

- Clamped, current supplying 4-20mA flow output none

Relay Output(s):

- ALARM1: SPDT 10A res. 125 Vac
 ALARM2: SPDT 10A res. 125 Vac

Wetted Material:

- 316 series stainless steel other _____

Enclosure:

- Class I, Group B, C, & D; Class II, Group E, F, & G; Class III; NEMA type 4X

Process Connection:

- male NPT thread flanged mount other _____

6.3 SPECIAL INSTRUCTIONS

REVISIONS			
REV	DESCRIPTION	DATE	APVD
A	Text correction	01/15/98	
B	Added note	7/27/05	

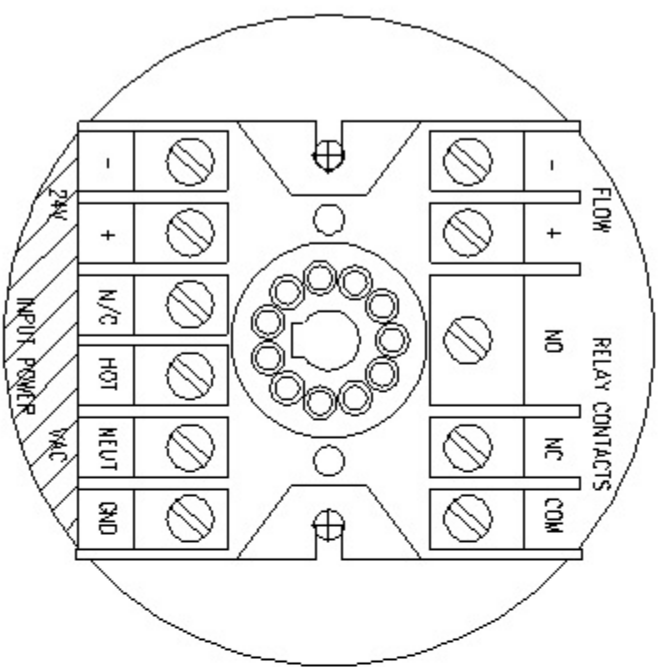

UNIT WITH 1 RELAY AND
THE 4-20 mA OUTPUT OPTION

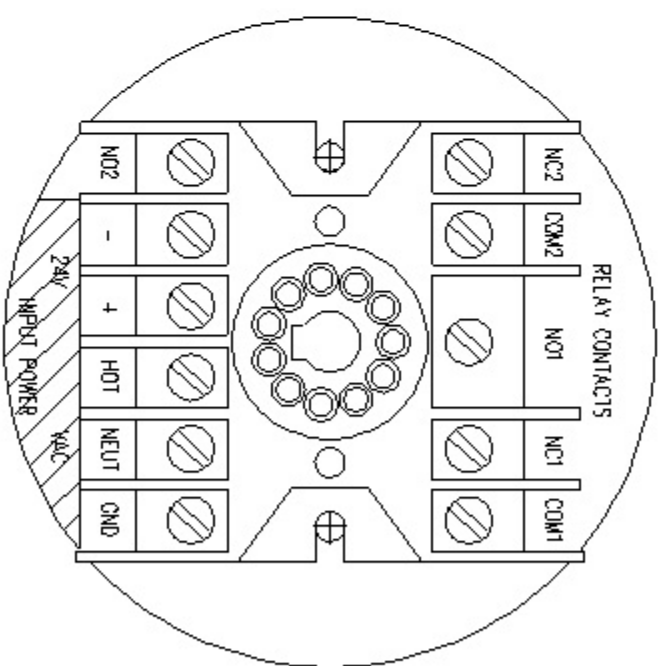

UNIT WITH 2 RELAY OUTPUTS

Note:
VAC can be 115 or 230

UNLESS OTHERWISE SPECIFIED DIMENSIONS ARE IN INCHES.	DATE	07/15/94	 Intek, Inc. 751 Intek Way Westerville, Ohio 43082
	DRAWN	JVR	
TOLERANCES UNLESS OTHERWISE SPECIFIED:	CHKD		MODEL 400 FLOW SWITCH FIELD WIRING INTERFACE
	APVD		
FRACTIONS = ± N/A DECIMALS X = ±N/A XXX = ±N/A ANGLES = ± N/A	APVD		SIZE CASE CODE DRAWING No. A 59936 94080-5
FILE 94080-5	CONTR		SCALE 1:1 SHEET 1 OF 1 MOUNT No