

TABLE OF CONTENTS

SECTION 1	GENERAL INFORMATION	- 1 -
1.1	INTRODUCTION	- 1 -
1.2	PRINCIPLE OF OPERATION	- 2 -
1.3	TECHNICAL SPECIFICATIONS	- 2 -
1.4	PRECAUTIONS AND RECOMMENDATIONS	- 3 -
SECTION 2	INSTALLATION	- 4 -
2.1	INSTALLATION	- 4 -
2.2	<i>RheoVac DR</i> SYSTEM INSTALLATION/SITE SELECTION	- 4 -
2.2.1	Probe Site Selection	- 4 -
2.2.2	Electronics Unit Site Selection	- 6 -
2.3	PROBE INSTALLATION	- 6 -
2.4	ELECTRICAL CONNECTIONS	- 8 -
SECTION 3	OPERATION	- 12 -
3.1	GENERAL INFORMATION	- 12 -
3.2	SYSTEM START-UP	- 12 -
3.3	PORTABLE USB DATA STORAGE/Warranty Registration Instructions	- 12 -
3.4	DISPLAY	- 12 -
3.5	COMMUNICATIONS	- 13 -
3.6	DATA PROCESSING	- 14 -
3.7	CUSTOM SOFTWARE	- 15 -
SECTION 4	MAINTENANCE	- 16 -
4.1	GENERAL MAINTENANCE	- 16 -
4.2	CALIBRATION	- 16 -
4.3	SPARE PARTS	- 16 -
4.4	TROUBLESHOOTING	- 17 -
4.5	HARDWARE AND SOFTWARE MODIFICATIONS AND UPGRADES	- 19 -
SECTION 5	CUSTOMER SERVICE	- 20 -
5.1	QUESTION ON EXISTING HARDWARE	- 20 -
5.2	TROUBLESHOOTING	- 20 -
5.3	FACTORY AND FIELD SERVICE	- 20 -
5.4	NEW EQUIPMENT AND SERVICES	- 20 -
SECTION 6	CUSTOM INFORMATION	- 21 -
6.1	UNIT IDENTIFICATION	- 21 -
6.2	CONFIGURATION	- 21 -
6.3	SPECIAL INSTRUCTIONS	- 21 -

Appendix A - *RheoVac* Instrument User Interface Software

Appendix B - *RheoVac DR* Networking

WARRANTY

Intek, Inc. warrants each *RheoVac DR* product to be free from defects in material and workmanship under normal use and service, Intek's obligation under this warranty being limited to making good any part or parts thereof which shall, within one (1) year after delivery of such product to the original purchaser, be returned to Intek with transportation charges prepaid and which Intek's examination shall disclose to its satisfaction to have been thus defective; this warranty being expressly in lieu of all other warranties, express or implied and all other obligation or liabilities on Intek's part. The purchaser will assume all responsibility and expense for removal, decontamination and reinstallation of equipment.

RheoVac instruments are manufactured under United States patent numbers 4,255,968, 5,485,754, 5,752,411, 6,385,974 and 6,526,755. Intek, *Rheotherm* and *RheoVac* are registered trademarks of Intek, Inc.

Intek, Inc.
751 Intek Way
Westerville, Ohio 43082-9057
Phone (614) 895-0301 Fax (614) 895-0319
web site www.intekflow.com
e-mail techsupport@intekflow.com
sales@intekflow.com

SECTION 1 — GENERAL INFORMATION

1.1 INTRODUCTION

For the first time, all necessary properties of the gases in the vacuum dryer exhaust line are directly measured to provide an accurate determination of water vapor removal and dryer performance related parameters. These properties are measured to provide the industry with the most advantageous and complete product for vacuum dryer system diagnostics:

the *RheoVac*® System*

*USPNS 4,255,648; 5,485,754; 5,752,411; 6,385,974; 6,526,755

A *RheoVac DR* system consists of sensor probes reporting to a central signal conditioner and processor unit. The sensing probes, consisting of multiple sensors configured in two separate probes (the standard configuration is a main FTP probe and a RS probe), is installed in the vacuum line, generally between the dryer and the exhauster. The *RheoVac DR* system is superior to all other methods in that it makes no assumptions about the dynamics of the dryer and vacuum line environment. The main FTP probe sensor head employs the patented *Rheotherm*® technology to provide an accurate mass flow measurement. Additionally, temperature, pressure and water vapor relative saturation measurements are made using a high accuracy platinum resistance temperature detector (RTD), a strain gauge pressure sensor and a specially configured and calibrated water vapor saturation sensor.

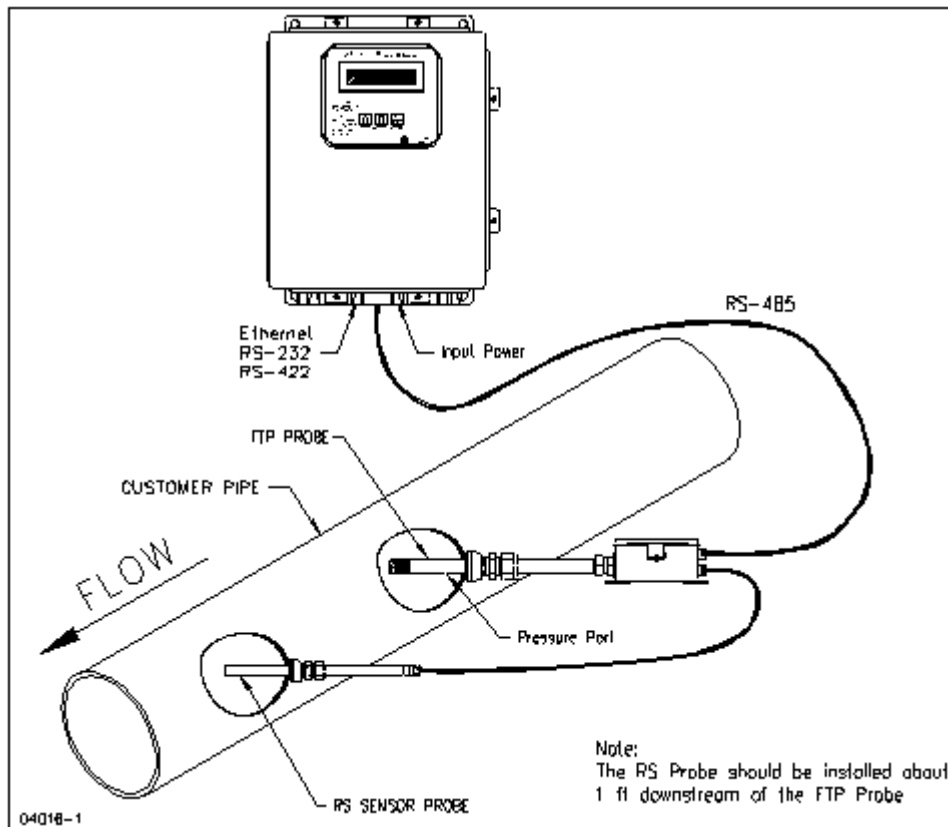

Figure 1 *RheoVac DR*

1.2 PRINCIPLE OF OPERATION

The principal features of the *RheoVac DR* system are shown in Figure 1. At the heart of the *RheoVac DR* system is the *Rheotherm* mass flow transducer, which uses the same patented thermal sensing technique employed in all precision flow instruments manufactured by Intek. Two temperature sensors are used – one sensor is in thermal equilibrium with the flow medium and provides a temperature and flow signal reference, while the second sensor is located near a constant power heater so that its temperature is always above that of the fluid. The temperature of the heated sensor will vary with the stream velocity of the fluid. Hence, the measured temperature differential between the reference sensor and heated sensor is a function of flow rate, which is approximately proportional to the logarithm of mass flow rate (USPN 4,255,968).

The *Rheotherm* flow sensor is calibrated to measure the total mass flow of the water vapor/air mixture. From the other three measurements - temperature, pressure and relative saturation - the *RheoVac DR* electronics converts the total mass flow signal from the probe into two components, air mass flow rate and water vapor mass flow rate. This unique measurement method is disclosed in two separate patents (USPN 5,485,754 & 5,752,411).

The *RheoVac DR* system is fully calibrated in the factory under dynamic fluid conditions similar to those within the dryer vacuum line. Typically, field adjustments are not required.

1.3 TECHNICAL SPECIFICATIONS

1.3.1 Sensor (Probe) Specifications

Primary Calibration Accuracy:

±5% of total mass flow

Repeatability:

±0.5% of reading

Operating Temperature:

Electronics: 40 to 120°F (5 to 49°C)

Probe: 40 to 160°F (5 to 71°C)

Never subject probe to temperatures above 210°F (99°C)

Operating Pressure:

0.5 to 30 inches Hg absolute

15 psi maximum

Storage Temperature:

-20 to 210°F (-29 to 99°C)

Storage Pressure:

15 psig (maximum)

Process Connection:

NPT

Hot tap assembly (optional, 1½” thread-o-let must be welded to pipe for hot tap installation)

Wetted Surface:

300 Series SS and engineered plastic

1.3.2 Main Electronics (Remote or PC) Signal & Data Access

Local Display:

- Back-lit LCD

- Selectable display of air mass flow and 6 additional instrument output parameters

- Parameter scrolling

- Metric/English units

Input Power:

- 100-250 Vac, 50/60 Hz

Signal Output or Data Access:

- RS-232/RS-422/Serial Modbus, Ethernet, TCP/IP

- Eight 4-20mA signals (optional)

- Wireless (Optional)

- OPC (Optional)

Temperature Environment:

- Operating: 40 to 120°F (5 to 49°C)

- Storage: -20 to 210°F (-29 to 99°C)

1.4 PRECAUTIONS AND RECOMMENDATIONS

Read the entire manual before installing and operating the *RheoVac DR* system.

Carefully select the best location for installation of the probe(s). Access, clearances, freedom from standing water, and straight-run should all be considered when selecting probe locations.

Use reasonable care in handling the probes the sensing components are delicate. Do not bend the probes, damage the tips, or obstruct the sensing ports. If shipping the unit, make sure the probes are adequately protected from foreign objects and damage; save and reuse factory provided custom probe protector and shipping boxes.

Use proper input power it must be between 100 and 250 Vac (nominal 120/240 Vac) at 50/60 Hz (60 Hz nominal).

Confirm the line and environmental temperature is always below the probe and electronics ratings never operate a probe at or subject it to temperatures or pressures beyond its specified limits. (See SECTION 1.3)

!! !! WARNING - Never allow live high temperature steam to flow either direction in the line where a probe is located.

Keep moisture out of the enclosures once all service connections are made, make sure the enclosure lids are tightly closed and all gaskets are in place. Seal all conduit lines.

The RJ45 is the recommended network connection for all data traffic (as opposed to serial and 4-20 mA communication).

Intek recommends a service contract to ensure probes are within calibration specifications and electronics are maintained with appropriate updates. Instrument probes should be returned to the factory for inspection and calibration service every two years.

SECTION 2 — INSTALLATION

2.1 INSTALLATION

These instructions are general guidelines for the installation of *RheoVac DR* instruments in their standard configuration. Additional information pertaining to your unit is covered in SECTION 6 CUSTOM INFORMATION. Carefully read these instructions prior to installing the equipment. Also, see preceding SECTION 1.4 PRECAUTIONS AND RECOMMENDATIONS.

2.2 *RheoVac DR* SYSTEM INSTALLATION/SITE SELECTION

The *RheoVac DR* can be configured with one or two probes, with the two probe being the standard configuration. In the standard two-probe configuration, the main probe (FTP) is the larger probe, and the relative saturation (RS) sensor is located in a second probe, separate from the remaining primary sensors in the FTP probe. The RS probe is typically installed in the same line at a location slightly downstream of the FTP probe.

2.2.1 Probe Site Selection

The location for the probe pair should be selected so as to provide the probe sensing area with well-established smooth flow, uniform system temperature and pressure, and consistent non-liquid phase flow medium. Pipe sections ahead of a probe, in which water can accumulate, must be avoided. Refer to Figure 2 and select the most preferred location for the probe pair. Do not install the probes beyond any “trap” sections as shown in Figure 2, Configurations B and D. Special installation instructions unique to your unit, where applicable, will be noted in SECTION 6.3 SPECIAL INSTRUCTIONS. Refer to this section now to review special instructions.

Check installation clearance. The installation location should allow sufficient clearance for ease of probe removal (for servicing), including the required clearance space for the hot tap, where used. Be sure there are no obstructions around the vacuum line that will interfere with probe insertion. Figure 3 shows the proper insertion angle. **THIS ORIENTATION IS IMPORTANT FOR PROPER OPERATION**, particularly if liquid water is expected to wet the wall surfaces of the probe(s).

Observe the selected sites; check for ease of access. They should be convenient for the removal and replacing probes at any time for service; without requiring ladders, building scaffolding or waiting for plant shutdown.

Check operating conditions. The temperature and pressure limits (see TECHNICAL SPECIFICATIONS; SECTION 1.3) of the unit should be checked to ensure compatibility with your application.

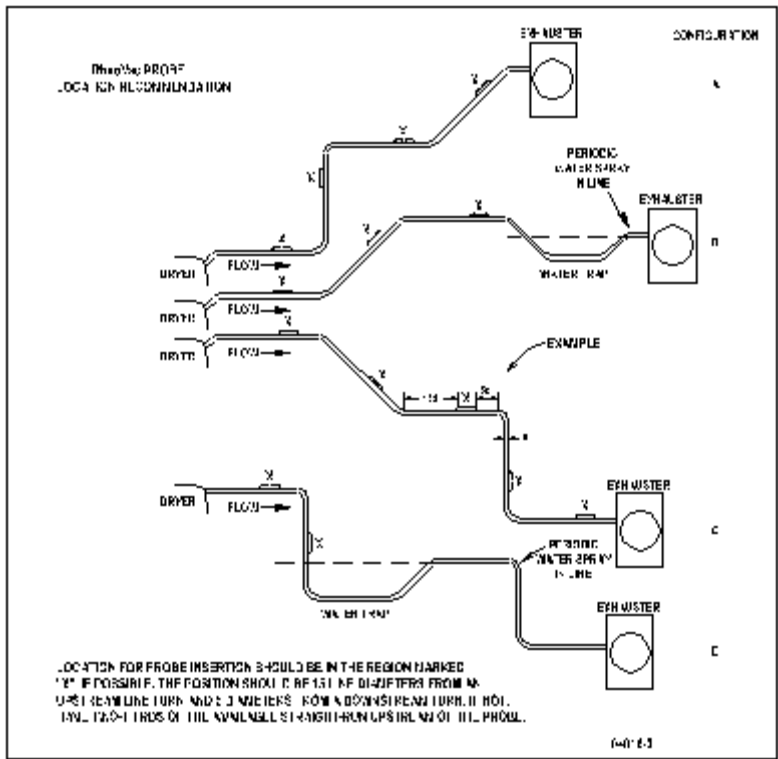

Figure 2 RheoVac DR Probe Insertion Recommendation

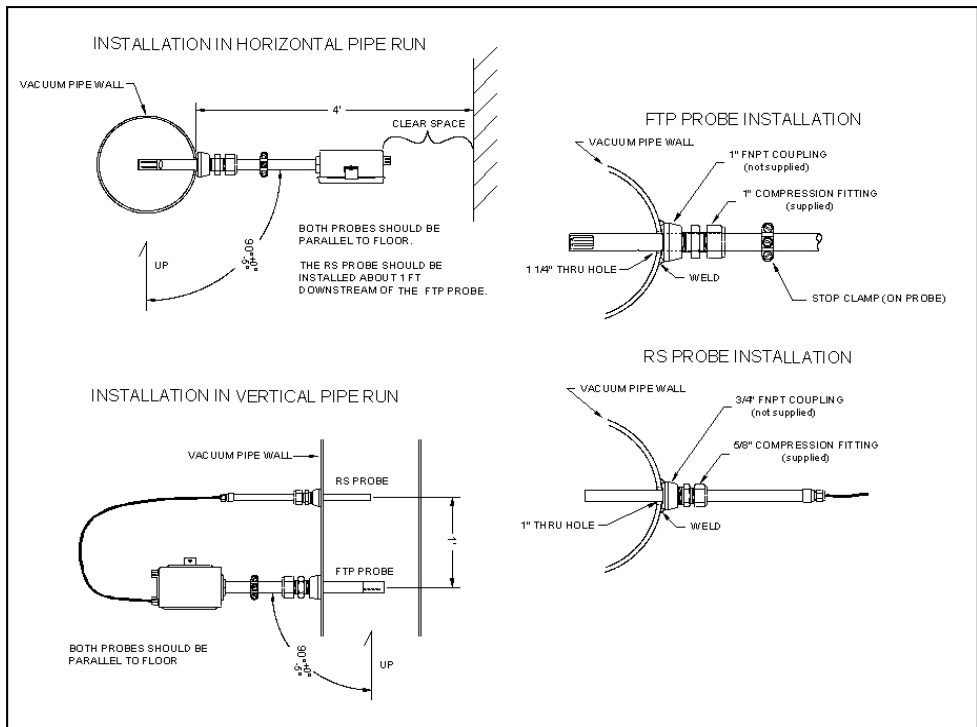

Figure 3 Probe Installation Detail

2.2.2 Electronics Unit Site Selection

The *RheoVac DR* system may have up to three electronics enclosures; a main processor box, an optional distribution box, and an optional transmitter box. These enclosures should be installed in a convenient indoor location and should be kept away from direct sources of heat. The maximum temperature rating of electronics is 120°F; ensure that this temperature will not be exceeded inside the enclosure. Once the wiring connections are made, close and latch down the box lid to protect the contents from damage and debris. The enclosures should be located in a dry area and should be kept clamped shut during normal operation. Do not allow water to get into the enclosures. If installed outdoors, build a roof over all enclosures to prevent potential water infiltration, or direct sunlight to overheat contents.

- A. Processor Enclosure: This 12x10 NEMA 4 enclosure houses the display and central processing unit. Input power (100-250 Vac, 50/60 Hz) is connected inside this enclosure. This enclosure should be installed in a convenient location and should be kept away from direct sources of high heat, such as uninsulated steam lines.
- B. Distribution Box (optional): This 8x6 NEMA 4 enclosure is typically located near the probe that is closest to the processor enclosure unit. It is connected to the main processor with an RS-485 bus DeviceNet™ cable, which can be hundreds of feet long. The probe and transmitter RS-485 cable connections are also made within this box. **The probe and transmitter cable lengths should be 15 ft. or less.**
- C. Transmitter Box (optional): This 10x8 NEMA 4 enclosure contains terminals for accessing the optional eight 4-20mA signals. It can be located in or near the control room so that the 4-20 wires do not have to be run from the plant floor. An RS-485 DeviceNet cable connects the distribution box to the transmitter box. (There are restrictions on how this can be done, so check manual SECTION 6, or contact the factory.)

2.3 PROBE INSTALLATION

!!WARNING!! The FTP probe and the RS probe(s) contain components and materials that have a temperature rating limit of 210°F. If line and fluid temperatures are anticipated to exceed this limit, the probe(s) must be removed from the vacuum pipe before and must not be reinstalled until the problem condition has passed. Failure to do this can result in severe damage to the sensor probe(s), especially when steam enters the vacuum pipe due to vacuum pump operating anomalies. If Steam Jet Air Ejectors are used, always remove the RS probe from the line before pump start up and do not reinstall the RS probe until stable operating conditions are achieved.

A. NPT/Hottap Installation

1. Check hardware. Verify that the probe slides easily through the NPT fitting or hottap assembly and pipe penetration hole.
2. Verify there are the necessary minimum probe insertion clearance four (4) feet- between pipe surface and any obstruction.
3. For NPT fitting installation, ensure that the threaded mating fittings (not provided) for mounting the sensing probe(s) are installed at the proper locations in the process line. Typically, 1" threaded couplings are needed for the FTP and the RS probes.

4. If using a hottap: install the mounting hardware; drill a 1½” through-hole, center the thread-o-let over the hole and weld it onto the dryer vacuum pipe; thread the hottap assembly into the thread-o-let. Use thread tape or pipe dope to seal the connection. Alternate: weld thread-o-let to pipe wall, then drill a 1½" hole in pipe wall using a hottap drill.
5. Make sure the probes are parallel to the floor (see Figure 3). Be sure location is accessible for probe removal and maintenance.

B. Installing/Removing the Probe

1. Check proper installation direction and probe orientation. The FTP probe has a directional arrow on the junction box. Before installing the unit, note proper flow direction. This is important to instrument operation.
2. Check serial number (S/N). If more than one *RheoVac DR* system has been purchased, make sure the first five digits of the serial numbers of the probe(s) match the first five digits of the serial number of the main processor unit. The electronics and probe pairs are a matched set. Mismatched components will not work correctly. The dash number on the probe S/N is the probe number shown on the display. Record the probe pair number and installation location for future reference.
3. Verify stop clamp location (see Figure 4). A stop clamp is attached to each FTP probe as an indication of its insertion depth. It is important that the stop clamp is securely in place to position the sensors in the correct location and to ensure that the probes do not contact the opposite pipe wall. Contact with the pipe wall could damage the probe. The clamp’s location is determined based on your submitted pipe diameter, as shown in SECTION 6.2, and is marked with a groove on each probe shaft. Refer to this mark if a stop clamp is inadvertently moved. When installed in the line, the sensors in the probe should be positioned in the middle of the pipe.
4. Prior to inserting probe, loosen the compression nut on the thermocouple connector of the hot tap or the NPT fitting and clean the inner surface of the thermocouple connector to ensure it is free of particles that may cause probe damage.
5. Be sure to power up your *RheoVac DR* instrument system and probe pair for at least 30 minutes before inserting probes into the vent line. DO NOT leave probes in vent line without power.
6. Install probes. The probes should be mounted through the pipe wall using the hottap assembly or NPT fitting.
 - a. The FTP probe installs so that the two sensor tips are side-by-side across the gas stream. Each probe has a flow directional arrow on the junction box. Make sure the probe orientation is correct.
 - b. The RS probe does not have an orientation requirement. The RS probe has a 4 foot (1.2 m) cable with a plug-in connector (with attached dust cap) for connecting to the FTP probe. Unscrew the dust caps on the RS cable and the FTP probe junction box, plug the cable connector in securely first, before inserting the RS probe in the line.

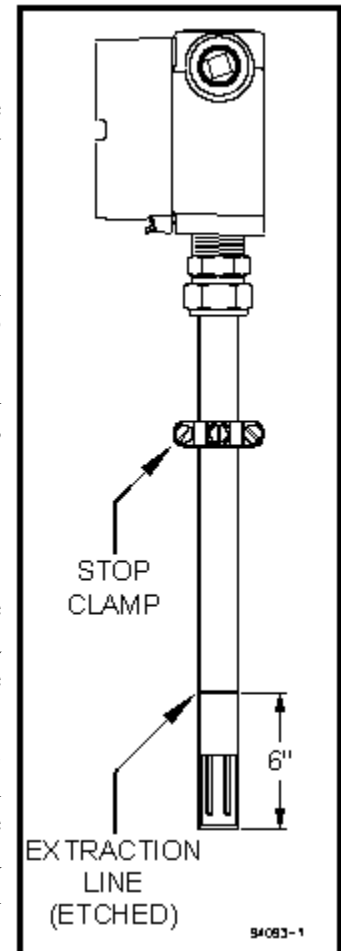

Figure 4 Probe Stop Clamp

7. When installing under vacuum, do not allow the clamp to “slam” against the seal nut upon opening the valve. Grasp each probe firmly, with hand against the seal nut, before opening the ball valve. Allow the probe shaft to slide slowly through the valve by controlling the amount of grip on the probe shaft. Do not let it slam against the seal nut. Once fully inserted, tighten the seal nut. Special installation instructions, if any, will be noted in SECTION 6.
8. It may be necessary to apply a force of about 23 lb (102 Newtons) to remove or replace the probe under operating conditions. Firmly grip the probe shaft when removing a probe from the line.

2.4 ELECTRICAL CONNECTIONS

IMPORTANT Inspect and **VERIFY** these electrical connections carefully. Improper connection could damage electronic components and sensor function. If additional holes need to be drilled in the processor enclosure, remove the electronics subassembly (mounted on a mounting plate) and temporarily store inside an ESD bag in a safe, clean place. Do not drill with electronics boards inside the enclosure.

A. Main Processor Unit (see Figure 5)

1. Sensor Power and Communication Line: Connect the distribution box to this main processor box using the RS-485 communications/power cable. Follow indicated connector color code. [*communications*: white (A), blue (B) and shield (SH); *power*: 24Vdc, red (+), and black (-)]
2. Main Power: Connect main power terminals to a dedicated 100-250Vac, single phase, 15-amp circuit. An external disconnect switch should be used for disconnecting power to the system during outages. Power connection wires should be at least 18 gauge and comply with accepted wiring codes. SW1 on the power input PWA (printed wiring board #01011-5) is used for cycling power to reset.
3. Network Connection (Recommended): The Ethernet connection at CN3 on the CPU interface PWA (printed wiring board #08017-1) is an RJ-45 style jack. A 10-foot Ethernet Cat5 crossover cable is supplied with the unit for laptop connections. Intek recommends using this connection for all data transmissions and *RheoVac* communications because:
 - a. More measured data is accessible through the network connection.
 - b. Software and calibration file updates can be done remotely.

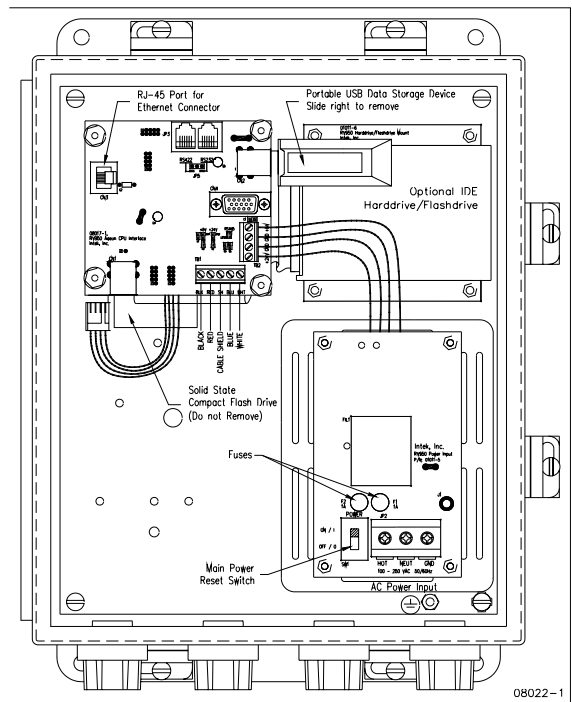

Figure 5 Electrical Connections and Set-up

4. **Serial Communication:** Connector JP3 on the CPU interface PWA (printed wiring board #08017-1) is the RS-232 serial communication interface. This interface should only be used for distances of 20 feet or less, such as to a laptop computer. A 20-foot serial cable with a DB-9 connector is available from Intek upon request (see Figure 6 and Table I). An RS-422 serial communication interface is present for long data communications when configured without 4-20 mA outputs. *Note: Intek recommends using the network connection for all data transmissions and RheoVac communications.*

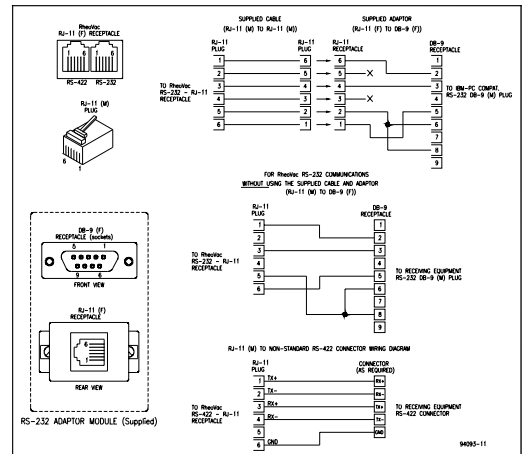

Figure 6 Serial Communication Interface

TABLE I. RJ-11 to DB Module Adapter

RS-232 CONFIGURATION			RS-422 CONFIGURATION		
RJ-11 Pin Out		DB-9 Pin Out	RJ-11 Pin Out		DB-9 Pin Out
1	Tx (transmit)	1 N/C	1	T x + (t r a n s m i t +)	1 Rx- (receive-)
2	N/C	2 Tx (transmit)	2	Tx- (transmit-)	2 Rx+ (receive+)
3	Rx (receive)	3 Rx (receive)	3	Rx+ (receive+)	3 Tx+ (transmit+)
4	N/C	4 N/C	4	Rx- (receive-)	4 N/C
5	Power (+5V)	5 Ground	5	Power (+5V)	5 Ground
6	Ground	6 Pulled high	6	Ground	6 Tx- (transmit-)
		7 N/C	7		7 TBD
		8 Pulled high	8		8 TBD
		9 N/C	9		9

B. Distribution Box (optional) (see Figure 7)

1. Connect the RS-485 wires (blue, white and shield) and 24Vdc power (red and black) from the main processor unit.
2. Install ½” liquid-tight conduit between the distribution enclosure and the probes unless ½” rigid conduit is used for long distance runs. Use a minimum of 6 feet of liquid-tight at the probes.
3. The probe connector comes with an adapter which allows the attachment of the ½” flexible conduit connector.
4. Connect the probes to the distribution enclosure using the manufacturer supplied four conductor shielded cable to any of the screw terminals labeled JP3 to JP6. Probe cable connections are shown in Figure 7.
5. Optional - Connect the transmitter box to the distribution box using the supplied RS-485 cable.

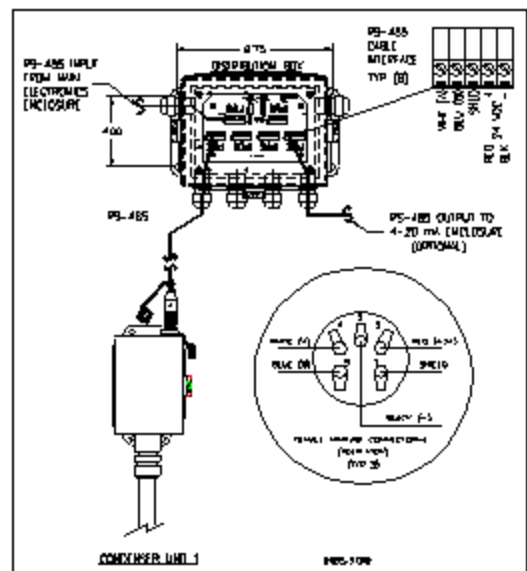

Figure 7 Distribution Box

C. Transmitter Box (optional, See Figure 8) - For driving eight (8) remote 4-20 mA analog signals from one RS-485 input port. *Note: Intek recommends using the network connection for all data transmissions and RheoVac communications.*

1. Connect the RS-485 communications/power cable from the distribution box (RS-485: white and blue wires; 24Vdc power: red and black wires).
2. Connect up to eight (8) signal wire pairs to the indicated terminals for isolated 4-20mA outputs.
3. Figure 8 provides the *RheoVac DR* wiring detail for the 8 channel 4-20 mA outputs. Table II provides the appropriate connection identification. Transmitters are configured as active (transmitter sources the current) when shipped. To change to the passive mode (receiver to source the current), extract each small 4-20 board, find the JP1 pins, and move the two jumpers from the "Act" pins to the "Pass" pins (two positions to the right of factory settings). Figure 9 shows the current output circuit. The figure also illustrates the active mode and the passive mode configurations.

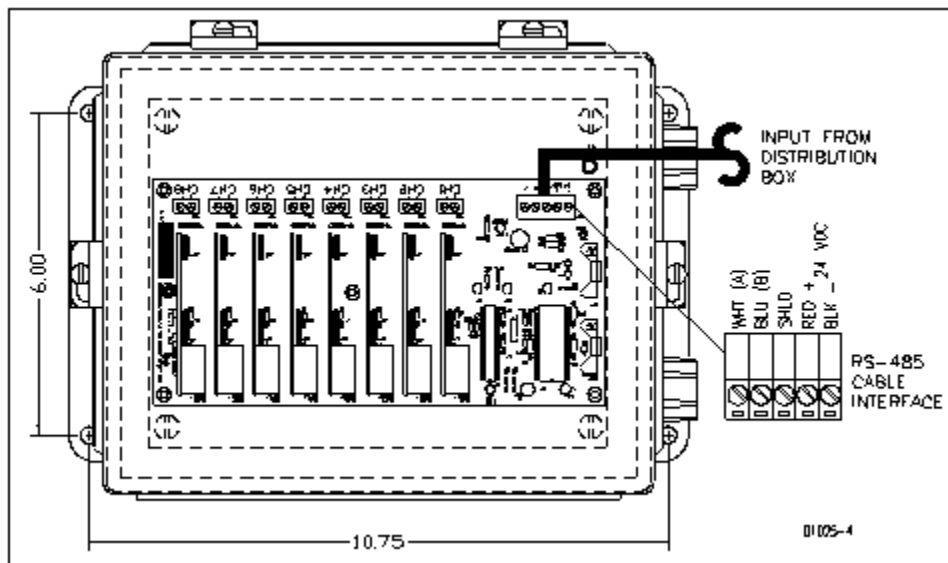

Figure 9 Optional Transmitter Box

TABLE II. Optional 4-20mA Configuration

Channel	Output Parameter
1	Actual Volume Flow
2	Total Mass Flow
3	Water Vapor Flow
4	Pressure
5	Water Vapor to Air Mass Ratio
6	Relative Saturation
7	Air Mass Flow
8	Temperature

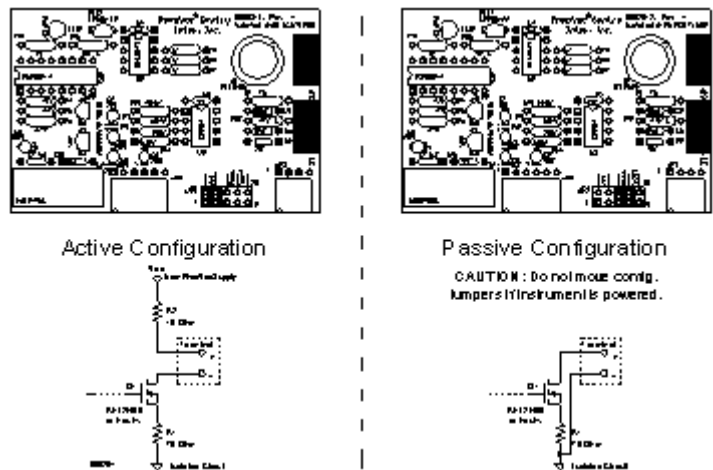

Figure 8 4-20 mA Output Circuit

D. FTP Probe: **CAUTION—Do not cross thread connection.** The FTP probe is supplied with a convenient plug-in connector. The male side of the connector comes installed in the probe junction box. The female side is usually shipped loose and must be installed onto the supplied DeviceNet type 5711 cable once it is run from the Distribution Box to the probe. The wiring detail for the female plug-in connector (Turck p/n B4151-0/9) can be seen in Figure 10. These connectors will use either the “backshell nut” or “conduit connector” depending on whether the cable is installed in a liquid-tight conduit. When installing without conduit, use the backshell nut; when using liquid-tight conduit, use the conduit connector with o-ring.

1. Slide all of the appropriate parts onto the cable as shown.
2. Strip the cable conductors as shown. The connector has 5 retention screws to hold the wires in place. The use of crimp pins on the wires will greatly increase connection reliability.
3. Loosen all 5 retention screws (do not completely remove).
4. Insert the wires, in accordance with color-coding shown (see Figure 10, insert).
5. Tighten the retention screws on each wire.
6. Reassemble the connector parts.

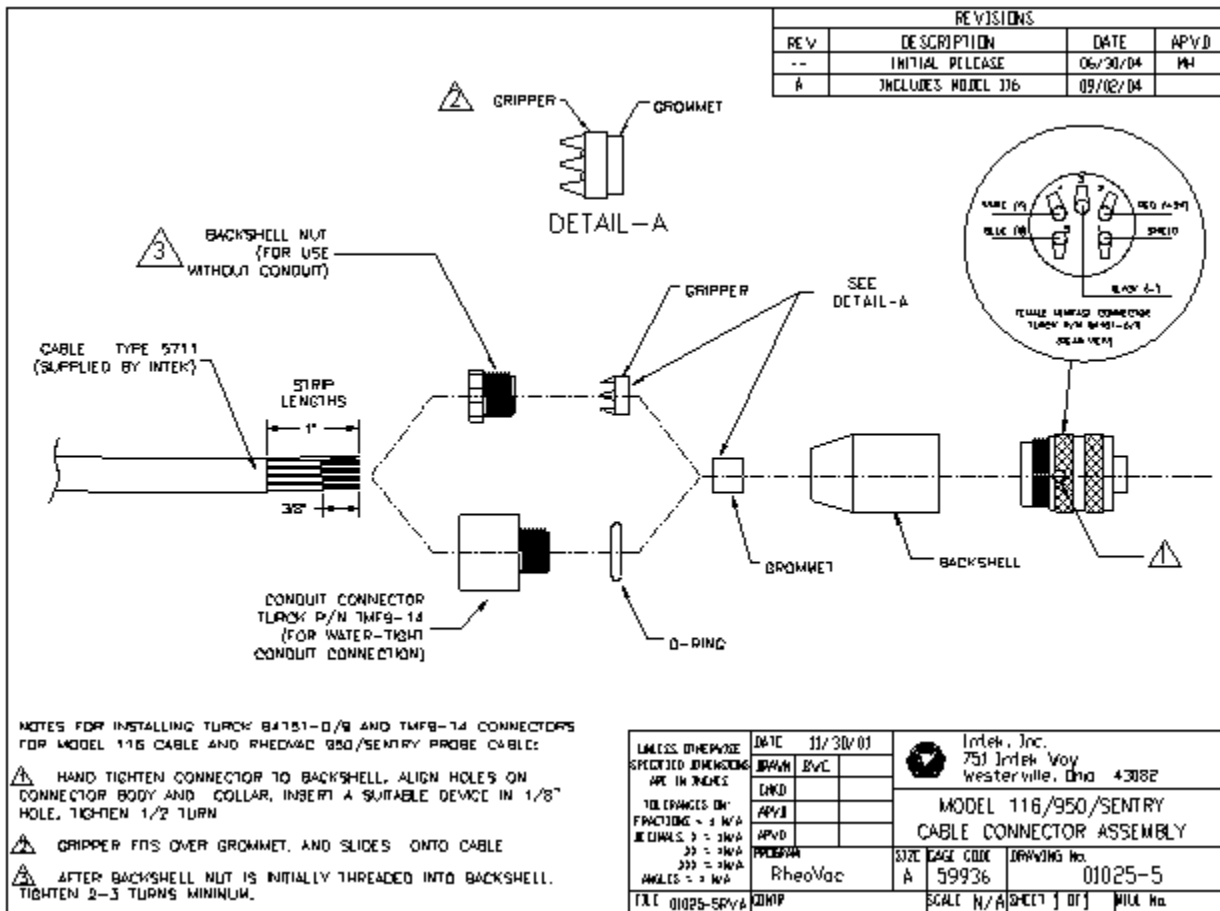

Figure 10 Probe Connector Assembly

SECTION 3 — OPERATION

3.1 GENERAL INFORMATION

The *RheoVac DR* system is compensated and linearized for a wide range of flowing medium temperatures, pressures, and water vapor content. However, abrupt changes in these parameters can cause the instrument to temporarily read improperly, which could lead to transient spikes in the flow indication. In particular, if liquid (water) contacts the probe tips, there will be high flow indications until all the water vaporizes. This is typically an infrequent occurrence and should not happen if the probe is properly installed, according to instructions in SECTION 2 INSTALLATION, and the vacuum dryer is operating according to design.

3.2 SYSTEM START-UP

Verify wiring is according to instruction in SECTION 2.4. With all power off, place the power *OFF/ON* switch, SW1, to “ON.” Close and latch down the main processor enclosure lid. While watching the main processor display, apply power to the instrument. After about twenty seconds the display should initialize to “*Health Check in Progress*” followed by additional initialization status messages. Within two minutes the display should indicate “Air Mass Flow” rate in lb/hr units.

Upon a “cold” initial start-up of the *RheoVac DR* system, the probe may take several minutes to give accurate readings. During this time the probe is transitioning to thermal equilibrium conditions under vacuum.

3.3 PORTABLE USB DATA STORAGE/Warranty Registration Instructions

Intek’s warranty program is stated at the front of the manual. To validate warranty:

- A. Locate portable USB Data Storage Device in the main electronics enclosure (Figure 5).
- B. Grasp bracket and carefully remove portable USB Data Storage Device.
- C. E-mail all *RheoVac DR* instrument data to techsupport@intekflow.
- D. Replace portable USB Data Storage Device in the main electronics enclosure.

CAUTION - Do not attempt to use non-Intek approved USB flash drives with the *RheoVac DR* instrument. Your *RheoVac DR* instrument may not have the proper drivers installed for other USB flash drives. This may cause the *RheoVac DR* instrument to lock-up and require service.

3.4 DISPLAY

The *RheoVac DR* has a 2x20 alphanumeric scroll-through display that shows seven parameters for the probe pair. The display shows Air Mass Flow, Water Vapor Mass Flow, Total Mass Flow, Temperature, Pressure, Relative Saturation, or Actual Volume Flow (as well as Time/Date, Software Version, Serial Number). To change the displayed parameter, press the *Scroll Up* or *Down* arrows. The display units can be changed from English or Metric units by pressing the *Units* button.

If the *RheoVac DR* is configured for multiple probe pairs, the display will show all the probe serial numbers one set at a time, one for each probe pair. The numbers will be in order, from the lowest serial number to the highest, reading from left to right on the display. Example: 11621-1, 11621-2 and 11621-3.

3.5 COMMUNICATIONS

A typical *RheoVac DR* instrument has an Ethernet port and two serial communications choices (RS-232 or RS-422). The ethernet port can communicate via Windows® network Modbus or OPC. Eight 4-20mA output signals for the probe pair are optional. Each process variable is a linear, fully temperature and pressure compensated value on any of these readable outputs. If supplied, all 4-20 mA output signals are scaled such that 4 mA represents 0% of the rated full scale value (except temperature, which is 0°C) and 20 mA represents 100% of the rated full scale value (temperature is 100°C). The standard full scale values and definitions of all process variables are listed in Table III. Communication with the *RheoVac* unit using Intek supplied software is discussed in Appendix A and Appendix B of this manual. *Note: Intek recommends using the network connection for all data transmissions and RheoVac communications.*

Table III. Process Variable Definitions and 4-20 mA (optional) Range

PROCESS VARIABLE	4-20 mA FULL SCALE	PROCESS VARIABLE DEFINITION
ACTUAL VOLUME FLOW ACFM [m ³ /hr]	5000 [8,500]	The actual volumetric flow rate of gases leaving the vacuum dryer. It is a measure of exhauster capacity. Decreased capacity means pump degradation.
TOTAL MASS FLOW lbs/hr [kg/hr]	10000 [4,536]	The total mass flow rate of the flowing gas. Note: this value is not a measure of air in-leak. It is a measure of total vapor and air removal and exhauster operating capacity.
WATER VAPOR MASS FLOW lbs/hr [kg/hr]	8000 [3,629]	The water vapor component of the flowing gas being removed from the vacuum dryer.
<i>RheoVac</i> PRESSURE "Hg [mm Hg]	30 [762]	Absolute pressure at the <i>RheoVac DR</i> probe head. Should be equal to or less than turbine back pressure.
WATER VAPOR SPECIFIC VOLUME (ft ³ /lb)	N/A	The inverse density of the water vapor present in the line. Not supplied as 4-20 mA output.
WATER to AIR MASS RATIO	20	Ratio of water vapor flow rate to dry air flow rate. Defines "vacuum quality."
RELATIVE SATURATION [%]	100	The percent concentration of water vapor in the extraction line relative to saturation.
PARTIAL PRESSURE, WATER "Hg (mm Hg)	N/A	The partial pressure of water vapor in the vacuum line. Not supplied as 4-20 mA output.
AIR MASS FLOW lbs/hr [kg/hr]	1000 [453.6]	Actual measure of air mass flow rate passing the <i>RheoVac DR</i> sensor head, normalized to standard conditions (70°F, 29.9" HgA).
<i>RheoVac</i> TEMPERATURE °F [°C]	212 [100]	4 mA = 0°C/32°F 20 mA = 100°C/212°F Temperature of the flow media at the <i>RheoVac DR</i> probe head.

3.6 DATA PROCESSING

A very important part of understanding your vacuum dryer system comes from evaluating the data that is created and stored by the *RheoVac DR* instrument. The ability to evaluate data has been greatly enhanced with the *RheoVac DR* by providing nearly unlimited data storage capacity. A data file is created for each calendar day that the monitor is operating. The ability to review stored data is invaluable when troubleshooting vacuum dryer problems. The column headings for each archived data file is seen in Table IV.

TABLE IV. Column Headings for Data Downloads and Archived Data

Time Stamp (Time of day)	Actual Volume Flow (ACFM)	Total Mass Flow (lbs/hr)	Water Vapor Mass Flow (lbs/hr)	<i>RheoVac</i> Pressure (Hg abs)	Water Vapor Sp. Vol. (ft ³ /lb)	Water to Air Mass Ratio (lb/lb)	Relative Saturation (%)	H ₂ O Partial Pressure (Hg abs)	Air Mass Flow (lb/hr)	Probe Temp. (°F)	RS Temp. (°F)	Raw Total Mass Flow (lbs/hr)	ΔT (°F)	RS Frequency (Hz)
-----------------------------	------------------------------	-----------------------------	-----------------------------------	-------------------------------------	-----------------------------------------------	------------------------------------	----------------------------	-----------------------------------------------	--------------------------	---------------------	------------------	---------------------------------	------------	----------------------

The importance of reviewing graphed data cannot be overstated. Reviewing data for normal operating conditions will greatly decrease the time need to troubleshoot problem conditions when they arise. To simplify the graphing process, an Excel add-in has been created by the technical support team at Intek. This Excel add-in graphing utility, called *RheoGraph*, is an automated graphing macro that imports and graphs *RheoVac DR* data files. It is available on request.

The *RheoGraph* utility is contained in a self-extracting zip file called "*RheoGraph.Rev...exe*" on the user interface software CD. Executing the file will begin the menu driven installation process. The default installation path is to C:\RheoVac; do not change this path name during installation. The file *RheoGraph.xla* will be copied to the installation folder along with help files, sample data, and a readme text file. Microsoft Excel is required for the add-in to function.

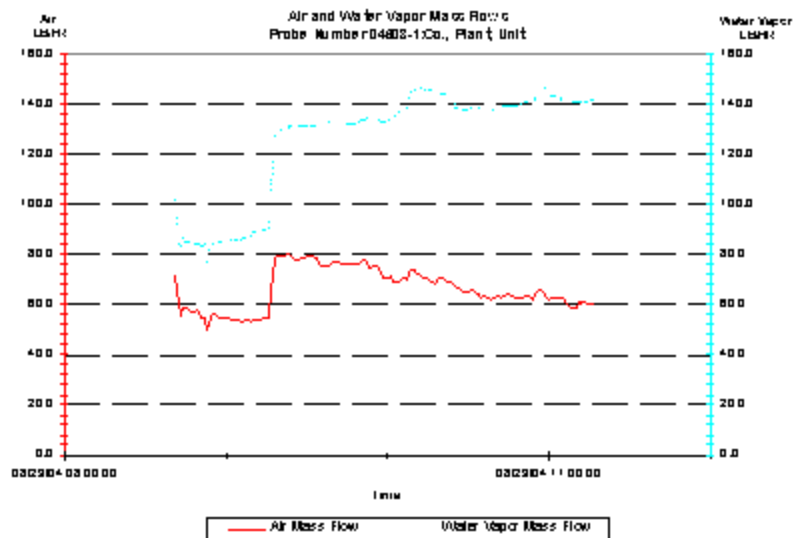

Executing *RheoGraph.xla* will launch Excel and the graphing menu will appear. Selecting Auto will prompt the user to enter Company, Plant, and Unit info, which will be placed in the graph titles. Then the user is prompted to browse to the data file to be graphed. The data will be inserted into a spreadsheet page and four graph pages will then be automatically added as separate tabs in the workbook. When the graphs are complete, macro execution terminates.

Several advanced features are available by selecting Advanced on the Auto Start menu. For additional help, use the keyboard arrow keys to set focus on any button, then press F1. An example is shown of a graph made by *RheoGraph* showing air mass flow and water vapor mass flow.

3.7 CUSTOM SOFTWARE

Custom software may be developed by the user to receive and archive *RheoVac DR* data into a computer system. The electronics has a serial data protocol of 9600 baud, no parity check, eight data bits and one stop bit (i.e., 9600,N,8,1). Each transmitted group of data is sent in a standard ASCII coded format representing each process variable value, instrument identification and status information.

The data stream consists of 13 fields, followed by a carriage return <RETURN>. The first ten fields, nine bytes each, are the process values. Following the process variables are the *RheoVac* serial number, nine bytes, the process identification tag number, 15 bytes, and the *RheoVac* system status, seven bytes. The data stream is then ended by a single <RETURN> byte (ASCII code 13). The total number of bytes transmitted in each data stream is 122 bytes per probe including the trailing <RETURN>. This data group is sent approximately once every three seconds. Table V shows the field names and number of bytes in one data stream.

TABLE V. Serial Output Data Stream

Actual Volume Flow (ACFM)	Total Mass Flow (lbs/hr)	Water Vapor Flow (lbs/hr)	<i>RheoVac</i> Pressure ("Hg abs)	Water Vapor Sp. Vol. (Cu. ft/lb)	Water to Air Mass Ratio (lb/lb)	Relative Saturation (%)	H ₂ O Partial Pressure ("Hg abs)	Air Mass Flow (lb/hr)	Probe Temp. (°F)	Instr. Serial Number	ID Tag No.	Status	Term. <CR>
9 bytes	9 bytes	9 bytes	9 bytes	9 bytes	9 bytes	9 bytes	9 bytes	9 bytes	9 bytes	9 bytes	15 bytes	7 bytes	1 byte

Each of the first ten process values are sent in the fixed decimal format of XXXX.XXXX with leading and trailing zeros inserted to maintain the nine character length. The next three fields are ASCII text strings followed by the <RETURN>. Example: The nine bytes for an air mass flow of 10.0 lb/hr would be: 0010.0000, or 48,48,49,48,46,48,48,48,48 ASCII.

SECTION 4 — MAINTENANCE

4.1 GENERAL MAINTENANCE

Precautions should be taken to insure proper performance of all sensors. Since the quantification technique involves signal measurements, care should be exercised to prevent build-up of dirt and/or corrosive layers on the probe surface and on the various terminal strip connections. Periodic checks with necessary cleaning should be performed to insure clean probes and terminals. The joints of the sensor leads should occasionally be inspected for corrosion or presence of moisture.

4.2 CALIBRATION

The *RheoVac DR* instrument is calibrated at the factory in a calibration system which replicates the vacuum dryer and vacuum line environment. The system is designed to calibrate the temperature, pressure, water vapor relative saturation and flow sensor under the gaseous fluid conditions found within the plant's vacuum line.

In general, calibrations should be valid over a two year period if the probes are well maintained. Should the unit require re-ranging or recalibration, note the serial number of the *RheoVac DR* instrument and contact the factory concerning recalibration cost and turn around times. Refer to SECTION 5 CUSTOMER SERVICE of this manual for additional information. Contact Intek for calibration, monitoring service plans, instrument service agreements as well as other Intek products and services.

4.3 SPARE PARTS

It is sometimes advantageous to have a spare probe pair. Should a spare probe pair be desired, it can be ordered and stored for installation at any time. A spare probe will come with a parameter disk with calibration files that will need to be uploaded to the main electronics along with instructions to complete the update and install/replace the probe (see SECTION 4.4).

Spare fuses should be available for replacement of blown fuses. Appropriate fuses to stock are:

- Electronics: Slow blow 1A Wickmann fuse, part number 3721100041 or equivalent.
- Probe: Slow blow 500 mA Wickmann fuse, part number 3720500041 or equivalent.

There are no other normally recommended spare components to stock.

To replace the fuse in the main electronics: locate the AC Power Input board (#01011-5 shown in Figure 5) in the lower right hand corner of the main electronics box. Slide the power switch to the “OFF” position to disable power to the electronics. The fuses are shown at locations F1 and F2 (spare). Gently pull the fuse(s) from the socket and gently insert the replacement 1 Amp fuse(s) as appropriate. Slide the power switch back to the “ON” position to enable power to the electronics. Close hinged lid and verify display backlight is on. Clamp close the enclosure lid, and tighten the latch screws.

To replace the fuse in the probe: locate the AC Power Input board (#01011-5 shown in Figure 5) in the lower right hand corner of the main electronics box, as above, to disable power to the probe. Gently pull the fuse from the socket and gently insert the replacement 500 mA fuse. Close the probe electronics lid.

Go to the main electronics enclosure and slide the power switch back to the “ON” position to enable power to the electronics and the probe(s). Close hinged lid and verify display backlight is on. Clamp close the enclosure lid, and tighten the latch screws.

4.4 TROUBLESHOOTING

Table VI provides a guide for plant personnel to identify causes of problems and determine appropriate actions to resolve problems observed. If problems are encountered and factory assistance is desired, please contact the factory.

TABLE VI. Troubleshooting Guide (diagnostic messages)

MESSAGE CODE Description/Symptom	PROBABLE CAUSE	ACTION
MSG-0 <i>Communications not being received from probe(s)</i>	<ol style="list-style-type: none"> 1. Improper cable hookup 2. Blown main fuse 3. Failed RS-485 circuit 4. Damaged flow sensor 	<ol style="list-style-type: none"> 1. Verify plug-in connector is mated 2. Check all cable connections 3. Check F1 fuse on probe board 4. Contact factory
MSG-1 <i>Invalid data received from probe(s)</i>	<ol style="list-style-type: none"> 1. Failed RS-485 communications component 	<ol style="list-style-type: none"> 1. Check wiring 2. Contact factory
MSG-2 <i>Flow sensor heater “OFF”</i>	<ol style="list-style-type: none"> 1. Blown heater fuse 2. Failed electronic component 	<ol style="list-style-type: none"> 1. Contact factory
MSG-3 <i>Relative saturation sensor power “OFF”</i>	<ol style="list-style-type: none"> 1. Probe temperature too high 2. Liquid water on probe tips 	<ol style="list-style-type: none"> 1. Check to be sure probe temperature is <160°F 2. Contact factory
MSG-4 <i>RS heater “OFF”</i>	<ol style="list-style-type: none"> 1. Component failure 	<ol style="list-style-type: none"> 1. Contact factory
MSG-5 <i>Circuit issue</i>	<ol style="list-style-type: none"> 1. Problem with circuitry 	<ol style="list-style-type: none"> 1. Contact factory
MSG-6 <i>Temperature alarm (above 210°F/99°C)</i>	<ol style="list-style-type: none"> 1. Steam in exhaust pipe 	<ol style="list-style-type: none"> 1. Remove probe or cool line ASAP! Once line has cooled down and probe is reinstalled, check unit for proper function.
MSG-7 <i>Wet probe</i>	<ol style="list-style-type: none"> 1. This usually indicates a vacuum dryer design or operation problem that requires corrective action. 	<ol style="list-style-type: none"> 1. Contact factory
MSG-8 <i>RS sensor problem</i>	<ol style="list-style-type: none"> 1. RS sensor problem 	<ol style="list-style-type: none"> 1. Remove from line, allow 24 hrs with power on to dry out RS, sensor, reinsert probe 2. Contact factory
Mass flow output saturates high , will not respond to flow changes	<ol style="list-style-type: none"> 1. Flow rate is not within range of calibration 2. Blown heater fuse 3. Failed electronic component 	<ol style="list-style-type: none"> 1. Contact factory about re-ranging instrument 2. Replace fuse 3. Contact factory
Mass flow output saturates low , will not respond to flow changes	<ol style="list-style-type: none"> 1. Flow rate is not within range of calibration 2. Failed electronic component 	<ol style="list-style-type: none"> 1. Contact factory about re-ranging instrument 2. Contact factory

When using the *RheoVac DR* software on a PC, the software may give you a “Communication Message.” Use the information in TABLE VII and TABLE VIII to determine the source of this problem and appropriate action.

TABLE VII. Troubleshooting Guide (serial connection software communication issues)

OBSERVATION	PROBABLE CAUSE	ACTION
<i>Appears the first time the application was executed</i>	<ol style="list-style-type: none"> Instrument not connected to the software defaulted serial port Communication connections not made or instrument is not powered 	<ol style="list-style-type: none"> Change serial comm port setting and hit “Retry” Check connections and instrument power
<i>Appears intermittently after application has been running normally</i>	<ol style="list-style-type: none"> Electrical noise interfering with communications Too many applications running in Windows® Another application is conflicting with this comm port or IRQ 	<ol style="list-style-type: none"> Change to RS-422 communications, re-route or shield cable Close other applications until problem self corrects Change to a different comm port
<i>Completely stops working after application was been running normally</i>	<ol style="list-style-type: none"> Instrument has stopped communicating Loose or damaged communication connection 	<ol style="list-style-type: none"> Check instrument power or look at instrument display for fault status Check cable adapter at back of PC or at any other splices or at instrument
<i>Cannot be made to work at all with Com3 or Com4</i>	<ol style="list-style-type: none"> Works fine on Com1 or Com2 but does not work on other port due to other hardware conflicts, such as a modem 	<ol style="list-style-type: none"> Using Windows Control Panel - System utility, check for IRQ or I/O hardware conflict - ADVANCED USERS ONLY

Note: Windows is a registered trademark of Microsoft Corporation in the United States and other countries.

If the *RheoVac DR* instrument is operating without fault mode indications but output readings are questionable, please send to Intek by telefax or e-mail at least 24 hours of data from the *RheoVac DR* instrument/probe, along with other relevant plant process parameters and control data for the same time period; an Intek engineer can review the data to provide support.

TABLE VIII. Troubleshooting Guide (ethernet connection software communication issues)

OBSERVATION	PROBABLE CAUSE	ACTION
<i>Connection error when attempting to connect to the instrument using the supplied User Interface Software (UIS)</i>	<ol style="list-style-type: none"> Incompatible network settings on the User Interface Computer (UIC) IP address not identified Bad or incompatible Cat5 cable 	<ol style="list-style-type: none"> Verify settings on the UIC outlined in Appendix B Reboot the UIC and <i>RheoVac DR</i> while connected Verify correct Cat5 cable (for peer to peer connection use crossover cable, for networked connection use straight cable) Contact factory
<i>Error occurs when attempting to use the UIS trending option or file update option</i>	<ol style="list-style-type: none"> Lost connection Incompatible UIS version 	<ol style="list-style-type: none"> Restart UIS Contact factory

4.5 HARDWARE AND SOFTWARE MODIFICATIONS AND UPGRADES

Note: The workgroup setting of the identification tab in Network Neighborhood Properties must be set to WORKGROUP which is the instrument default setting. A Cat5 crossover network cable is required for proper Ethernet network communication to the *RheoVac DR* instrument.

Normally, updating the main software residing on the *RheoVac DR* should be done at the factory. However, software improvements or other factors may necessitate a user installation or upgrade of a new main program. When this is required, instructions and software, as applicable, will be supplied.

If it is necessary to replace a probe, a new probe and diskette (with probe-specific calibration data), can be ordered from Intek.

SECTION 5 — CUSTOMER SERVICE

Intek's corporate philosophy is to help solve our customers' difficult flow measurement problems. When you purchase a *RheoVac DR* system you also receive Intek's dedicated customer service. For sales or product service, call your local representative or Intek directly at (614) 895-0301 8AM to 5PM EST/EDT weekdays or fax us anytime at (614) 895-0319. E-mail inquiries should be sent to sales@intekflow.com or techsupport@intekflow.com. Our customer service staff will provide assistance promptly.

5.1 QUESTION ON EXISTING HARDWARE

To allow us to help you more quickly, please have the serial number of the equipment available before you call.

5.2 TROUBLESHOOTING

If you have reviewed SECTION 4.4 TROUBLESHOOTING and have questions, please call our experienced engineers for assistance. In many cases we can solve a problem over the phone. Please provide as complete a description as possible of the problems encountered.

5.3 FACTORY AND FIELD SERVICE

If you request field service to help with vacuum system performance problems, Intek has, for a fee, experienced engineers available to meet your needs. For *RheoVac DR* instrument related questions, if a problem cannot be solved over the phone, with your help, we will determine if factory service or field service will be the best solution. When returning instruments/probes for factory service be sure to carefully pack the instrument/electronics; extra care should be taken to protect the probes from damage in shipment. Use the factory supplied PVC probe protection tube and custom shipping box for probes when possible.

To request factory service on your instrument, a Return Material Authorization (RMA) and purchase order is required. Our customer service staff will assist you with the required information to return instruments for service.

5.4 NEW EQUIPMENT AND SERVICES

For information on Intek's other instruments and services, such as a new *RheoVac DR* system, cooling water flow and fouling meters, liquid or gas flow meter or flow switches, dryer system inspection, analysis, or monitoring services, contact the Intek technical sales department by phone/fax/email. Our staff will be pleased to answer all questions and provide our recommended solutions, instruments, or services.

SECTION 6 — CUSTOM INFORMATION

6.1 UNIT IDENTIFICATION

Model no.: _____

Serial no.: _____

Customer identification: _____

Calibrated for customer line size of _____ inches, schedule _____

6.2 CONFIGURATION

The marked (X) items denote the configuration of this unit, as originally shipped from the factory.

Pipe Connection: 1" MNPT connection for FTP (main, larger) probe
 1" MNPT connection with adapter for RS probe
 Hot tap with _____ MNPT connection

Input Power: 100-250 Vac, 50/60 Hz

Outputs:

 Analog: 8 outputs (4-20mA) for the probe (See Table III)

 Digital: Ethernet
 RS232/RS422

Software: RV User Interface Software and Rheograph utility on CD

Data Access: Ethernet communication

Portable Data Storage: Portable USB Data Storage Device

Enclosures Shipped:

Processor Box
 Distribution Box
 Transmitter Box

Cables Shipped:

5711 Interconnect cable (RS485) - _____
 Cat5 Ethernet cable - 10 ft
 RS232 communication - 20 ft

6.3 SPECIAL INSTRUCTIONS

The next page shows a sketch of a typical layout for a *RheoVac DR* system with all components located near each other on the plant floor. Other configurations can be used, but there are rules as to how an RS485 signal can be run, so if you are considering the use of significantly different arrangement for your installation, please contact the factory (614-895-0301) to review your plans.

APPENDIX A - *RheoVac*[®] Instrument User Interface Software

A.1 INTRODUCTION

User Interface Software (UIS) is provided on CD-ROM with every *RheoVac* instrument. This software is used to communicate with the *RheoVac* unit from a User Interface Computer (UIC). Some of the functions of the software can be performed using a serial cable, while all functions are available using an Ethernet connection. An Ethernet crossover cable is provided with each *RheoVac* instrument for the purpose of connecting a UIC directly to the *RheoVac* unit. The network functions are also capable of being used from any network computer if the *RheoVac* instrument is connected directly to the same network. In this case, the supplied crossover cable is not used; rather a straight, high noise-immune Ethernet cable with RJ-45 plug is used (supplied by customer).

Most details regarding use of the software can be found in the active help files from the pull down **Help** menu when using the software.

A.2 SOFTWARE INSTALLATION

A User Interface Computer (UIC) is required to access stored data and real time data of all parameters. A laptop is suggested for easy access to the main processor unit. Intek does not supply UICs but recommends the following System Requirements (minimum recommended):

Minimum System Requirements:

- Windows 98, Windows NT, Windows 2000 or Windows XP Operating Systems
- Pentium III, 400 MHZ processor with 128 MB RAM
- SVGA 800 x 600 display
- One CD-ROM drive
- One 10/100 Ethernet Port

Recommended (Optional):

- One 3.5 inch floppy disk drive (probe recalibration data files can be provided on diskette)
- One RS-232 serial port with DB-9 connector

The User Interface Software should be installed onto the User Interface Computer. Install the software by inserting the CD-ROM supplied with the manual into the CD-ROM drive and follow the on screen prompts. A folder, C:\RHEOVAC will be created and files will be copied to this folder. The executable file is **RheoVac User Interface.exe** and the others are drivers and configuration files that must remain in the RHEOVAC folder. If a previous version of User Interface Software is on the UIC, you will need to launch the installer a 2nd time.

A.3 USER INTERFACE SOFTWARE (UIS) SELECTION

After installation, the user interface is initiated by selecting [START\PROGRAMS\RHEOVAC\RHEOVAC USER INTERFACE]. The main menu appears, prompting for a selection of RS-232 Serial Communication or Ethernet Communication Utility. A list of functions for each utility appears below the green selection buttons.

Make sure the proper cable connection has been made and select the desired communication type by clicking on either green button.

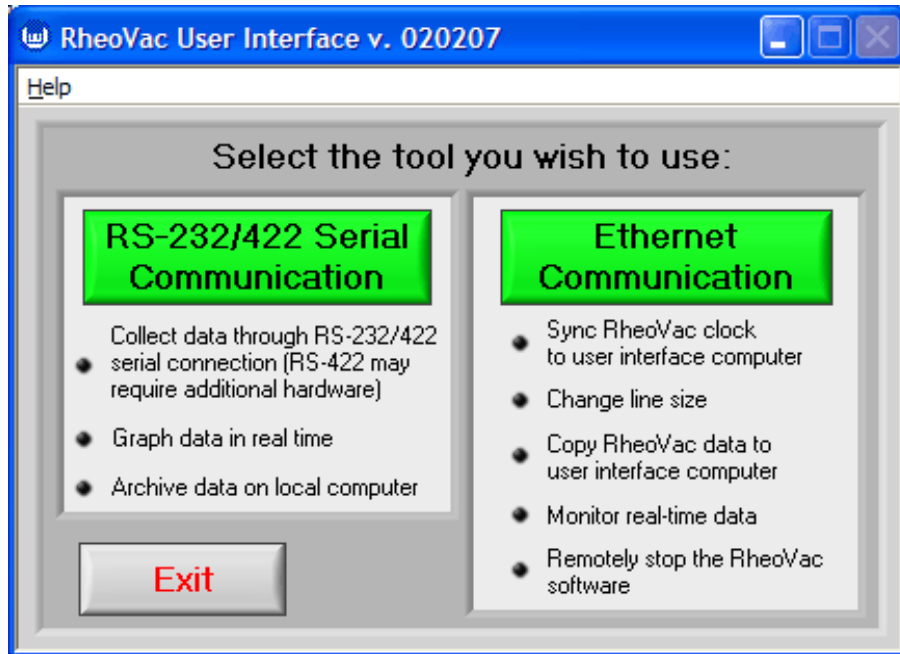

Figure A - Initial UIS computer Screen

A.4 RS-232/422 COMMUNICATION

This function requires a serial cable and connector, available on request, to connect the UIC and the *RheoVac* instrument electronics. This connection allows the user to view real time data of important parameters in a convenient gauge screen layout. From this gauge screen, the user may choose to graph a single parameter for all probes, graph all parameters for a single probe, or archive data directly to the UIC. The archive rate can also be adjusted. These are the only functions available using serial communication. No commands or updates can be sent to the *RheoVac* instrument using this communication method.

A.5 ETHERNET COMMUNICATION

User interface using Ethernet connection allows the user to: synchronize the *RheoVac* clock with the UIC clock, retrieve stored data¹, update files¹, change line size, and access data. These network access utilities are performed from a user interface computer (UIC) connected directly (peer-to-peer) to the *RheoVac* unit using a crossover network cable or from a network computer when the *RheoVac* instrument is connected to a network (LAN/WAN)² using a straight Ethernet cable.

Each *RheoVac* instrument is identified by a unique network ID. The ID begins with the letter “R” followed by the first five digits of the serial number found on the unit. (*RheoVac* Model 950 devices which have not been serviced by the factory since 2005 may use the serial numbers or “*RheoVac*

¹ File transfer can also be accomplished using Windows Explorer or Network Neighborhood

² Specific network set-up at Intek may be required.

950" network ID). The user must select the network ID from the pull down menu following the selection of Ethernet Communication utility from the Main Menu. If the Network ID is not in the list, select Add New ID and enter the correct six character Network ID. When a new ID is added to the list, it will be saved as the default for later use. Selecting the correct ID will initiate communication with the *RheoVac* instrument. Software features, in addition to those detailed above, are described within the User Interface Software itself.

A.6 SOFTWARE OPERATION

1. Set Clock (available with Ethernet connection only): Initiating this action will reset the *RheoVac* time clock to agree with the time on your UIC. Make sure the UIC has the correct time before proceeding.
2. Change Line Size (available with Ethernet connection only): Use this option to update the instrument's stored line size variable for proper volume and mass flow calculations. You should only need this option if the probe is installed in a pipe size that is different from the value set in the instrument at the factory. In Ethernet Communication, click on the Line Size tab. On the pull down menu for pipe size, click on the new value, then click on **Save**. Click **Load** to verify that the change was saved by the instrument.
3. Update Files (available with Ethernet connection only): If the probes are ever returned for recalibration, or some other change in the *RheoVac* operating software is needed, this tab will be used. Do not use it until then. Instructions will be supplied at that time.
4. Retrieve Data (available with Ethernet connection only): Stored data can be easily accessed via Ethernet connection from the *RheoVac* instrument to the UIC.

The *RheoVac* software creates a new data file each day. The file name is in the following format:

MMDDYY - P.dat
where MM = two digit month
DD = two digit day
YY = two digit year
P = probe designator (1, 2, or 3)
.dat = file extension

These data files are stored in tab delimited text format. See SECTION 3.5 to process data.

To copy a file for analysis, you must access the files on the *RheoVac* instrument. Open Windows Explorer on the UIC. Type \\Network ID\RHEOVAC\DATA (*Network ID* is generally "R" plus the first 5 digits of the serial number; see section A.5) on the address line and press enter. **Be careful not to alter any support files in this data folder.** Use the copy/paste functions (copy - Ctrl C; paste - Ctrl V) to put data files (.dat) on the UIC.

5. Monitor Data (available with Ethernet or RS-232 connection): Once RS-232 or Ethernet is selected, the first screen, Figure B, shows the most recent value for each parameter.

Click on the small graph image to view a historical graph of that parameter. Select from all available probes by clicking on the **Probe S/N** menu.

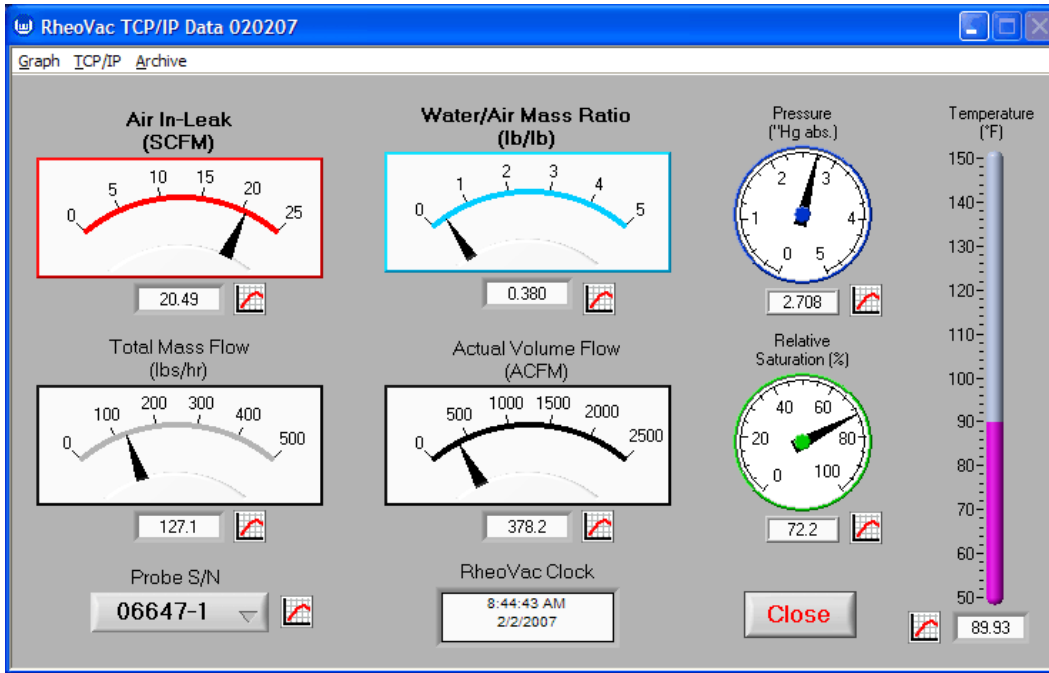

Figure B - User Interface Software Data Monitor Feature

To do real-time graphing, select from the graph menu. The screen shown in Figure C appears.

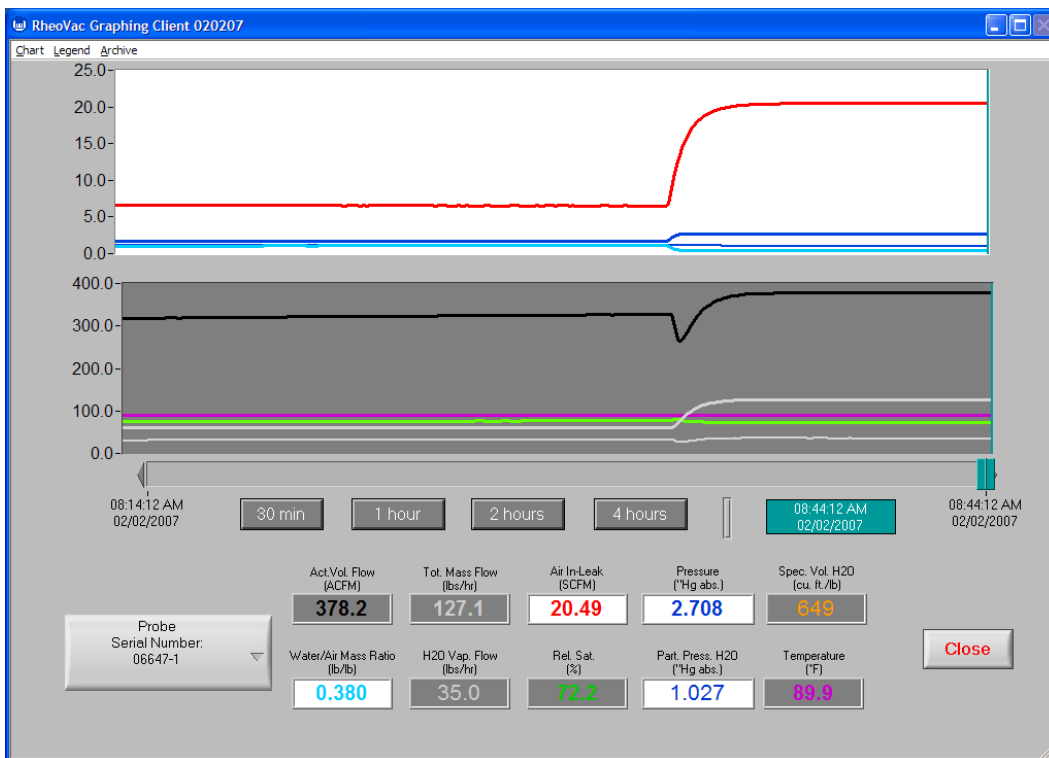

Figure C - User Interface Software Graph Feature

This screen can be divided into four parts:

1. The Chart (or charts)
2. The X-Axis Controls
3. The Legend
4. The User Menu

These four parts work together in the following ways: As soon as the software is opened and valid communication is established, the data collected for each probe is plotted on the chart(s). The newest data points are displayed on the right of the chart and push older data points to the left, much like many old-style strip chart recorders.

The horizontal scroll bar immediately below the chart(s) can be used to select which data points (i.e., data from a specific timestamp) from the chart are displayed on the legend below. Data points can be selected either by clicking-and-dragging the scroll bar pointer or by simply single-clicking a spot on the scroll bar.

The four buttons below and to the left of the scroll bar labeled **30 min**, **1 hour**, **2 hour**, and **4 hour** can be used to quickly set the x-axis range of the chart(s) and the scroll bar. When using these buttons keep in mind that the maximum x-axis value is always used as a reference and only the minimum displayed x-axis value will be changed. You can also change both the minimum and maximum x-axis value by double-clicking them with your mouse and entering a new value with your keyboard. Changing the range of the chart (X or Y axis) changes only the data that is displayed and does not delete or alter the data in any way.

The blue block (time/date) to the right of the **4 hour** button displays the timestamp for the data point currently being pointed to by the horizontal scroll bar. If the scroll bar is in the right-most position, this value will automatically update when new data is received from the connected instrument.

The legend at the bottom of the screen displays the value of the data being pointed to by the scroll bar and also is used to control where each data parameter is plotted. To access this feature single-click on any parameter in the legend. Two things will happen. First, the background color of the selected parameter will change in the legend, and second, the parameter will disappear from the chart if you are in single-chart mode or jump from one chart to the other if you are in dual-chart mode.

Single-chart and dual-chart modes are the first two selections available in the chart user menu. Also available in the chart menu are selections to choose between manual and auto scaling for the y-axis and to reset the maximum x-axis value to the most recently collected data point.

The legend menu is used to select which parameter or which probe is displayed. If a parameter is chosen from this menu, that parameter will be displayed for all probes connected to the instrument. If a probe is selected, then all parameters for that probe will be displayed.

The archive menu is used to set the rate that data will be archived to the hard disk of the computer on which the user has installed the User Interface Software. These selections have no effect on the data that is stored every minute on the hard disk of the *RheoVac* instrument itself. Data archived

to the user's hard disk is stored in the "C:\RHEOVAC\DATA\" directory. The data is subdivided into folders for each probe. A new file for each probe will be created each day that data is archived.

A.7 WARRANTY REGISTRATION/TECHNICAL SUPPORT

Sending Data to Intek: **!!!! IMPORTANT !!!!**

If the instrument is equipped with a portable USB data storage device as shown in Figure 5 (in the main manual), remove this storage device after one week of operation and send to "Intek, Inc., 751 Intek Way, Westerville, OH 43082" to activate/secure warranty registration. This storage device is programmed to capture the initial baseline data recorded by the *RheoVac* instrument.

The following paragraph is applicable to *RheoVac* 950 instrument users only:

The availability of plant data for periods corresponding to the *RheoVac* data are important to proper diagnostic evaluation. Plant data of interest to the factory for the same time period are: turbine back pressure, hotwell temperature, load, and inlet and outlet circulation water temperatures. The plant data is necessary for correlating *RheoVac* measured data. The availability of this information at the factory is very important to Intek's ability to assist you in troubleshooting your instrument and/or to respond to inquiries. This provides a baseline for the system and will help us support you should future system problems arise. Our experienced support engineers can access the "before" and "after" effects of an upset and work with you to identify and understand the problem, and develop solutions. Additionally, most air removal piping conditions that are detrimental to probe operation can be diagnosed before probe damage occurs. For this reason, we require a data download one week after the *RheoVac* system is placed into service. The download activates the one year warranty service.

Alternately, you may send to the factory an initial week or so of data (zipped format is preferred). The simplest way is to copy all data files and the 'event.log' file to your UIC and send it via email to techsupport@intekflow.com.

Note: Windows is a registered trademark of Microsoft Corporation in the United States and other countries.

APPENDIX B - *RheoVac DR* Networking

B.1 INTRODUCTION

Use these instructions when making a peer-to-peer Ethernet connection between the *RheoVac DR* and the User Interface Computer (UIC), or an Ethernet connection between the *RheoVac DR* and a LAN. Locate the section that covers your operating software.

B.2 WINDOWS® 98, or Windows® ME

1. Ethernet Cable:
 - a. UIC Connection: use CAT5 network crossover cable (supplied by Intek) to connect the Ethernet port of the UIC to the Ethernet port on the *RheoVac DR*.
 - b. LAN Connection: use CAT5 straight high noise-immune Ethernet cable (not supplied) with RJ45 plug to connect the Ethernet port of the LAN to the Ethernet port of the *RheoVac DR*.
2. Workgroup Identification: Unless otherwise requested, the Workgroup identification for the *RheoVac DR* will be WORKGROUP, which is the instrument default setting. To check/set the workgroup name: Right click on the Network Neighborhood icon on the UIC desktop. Select Properties from the menu that appears. Select the 'Identification' tab of the Network dialog box that appears. Verify that Workgroup is WORKGROUP.
3. Check for Installed Network Components: Right click on the 'Network Neighborhood' icon on the UIC or LAN computer desktop. Select 'Properties' from the menu that appears. Select the 'Configuration' tab of the Network dialog box that appears. In the list under "The following network components are installed" there should be all three of the following: Client for Microsoft Networks, Ethernet adapter, and NetBEUI (with the Ethernet adapter identified on the same line next to it). Each will have a different icon associated with it; the 'Client' icon looks like a computer screen, the 'Adapter' icon looks like an adapter card, and the 'NetBEUI' protocol icon looks like a cable in a T shape. If these components are not installed, one or more of the following installations may be necessary. Note, the Windows installation disk may be needed.
 - a. Installing Client for Microsoft Networks: If Client for Microsoft Networks is not in the list of "The following network components are installed" then, do the following:
 - i. Click the 'Add' button next to the list.
 - ii. The Select Network Component Type dialog box will appear.
 - iii. Select 'Client' from the list then click the 'Add' button.
 - iv. Select 'Microsoft' from the Manufacturers list.
 - v. Select 'Client for Microsoft Networks' in the Network Clients list
 - b. Installing NetBEUI: If the NetBEUI (with the Ethernet adapter identified on the same line next to it) is not in the list of "The following network components are installed", then do the following:
 - i. Search the installed network components list for the installed Ethernet adapter.
 - ii. Select the 'Ethernet adapter' and click the 'Add' button below the list.

- iii. Select 'Protocol' from the Select Network Component Type dialog box.
 - iv. Click the 'Add' button next to the list.
 - v. The Select Network Protocol dialog box will appear.
 - vi. Select 'Microsoft' from the Manufacturers list.
 - vii. Select 'NetBEUI' from the Network Protocols list.
4. Networking with the *RheoVac DR*: If all of the items above are completed successfully, the UIC or LAN computer should be able to network with the *RheoVac DR*. To search for the *RheoVac DR* from the UIC or LAN computer:

Method 1

- Open Network Neighborhood.
- Each *RheoVac* instrument is identified by a unique network ID. The ID is an "R" plus the first five digits of the serial number found on the unit.
- Look for the Network ID of your *RheoVac DR*. If the expected Network ID (See previous paragraph) does not show up in the list, then type in the appropriate Address line (\\ "R" plus the first five digits of the serial number) and click the 'Go' button. This may take several seconds and then a RHEOVAC folder will appear, which is the hard drive of the *RheoVac DR*.
- Open the RHEOVAC folder then open the DATA folder. The *Network ID* \RHEOVAC\DATA folder contains all the stored data. Use Windows copy/paste (COPY - Ctrl C; PASTE- Ctrl V) to save the data files to the UIC or LAN computer.

Method 2

- Open My Computer
- Type in the Address line: *Network ID* (*Network ID* is defined above) and click the 'Go' button. This may take several seconds and then a RHEOVAC folder will appear, which is the hard drive of the *RheoVac DR*.
- Open the RHEOVAC folder then open the DATA folder. The *Network ID* \RHEOVAC\DATA folder contains all the stored data. Use copy/paste functions to save the data files to the UIC or LAN computer.

B.3 WINDOWS NT, 2000

1. Ethernet Cable:
 - a. UIC Connection: use CAT5 network crossover cable (supplied by Intek) to connect the Ethernet port of the UIC to the Ethernet port on the *RheoVac DR*.
 - b. LAN Connection: use CAT5 straight high noise-immune Ethernet cable (not supplied) with RJ45 plug to connect the Ethernet port of the LAN to the Ethernet port of the *RheoVac DR*.
2. Workgroup Identification: Unless otherwise requested, the Workgroup identification for the *RheoVac DR* will be WORKGROUP. To check/set the workgroup name: Right click on the 'My Computer' icon on the UIC or LAN computer desktop. Select 'Properties' from the menu that appears. Select the 'Network Identification' tab of the System Properties dialog box that appears. Verify that Workgroup is WORKGROUP.
3. Check for Installed Network Components: Click the 'Start' button, select 'Settings', select 'Network and Dial-up Connections'. Or, right click 'My Network Places' and select

'Properties'. Highlight the Local Area Connection that represents the Ethernet adapter. Right click on 'Local Area Connection' and select 'Properties'. Under "Components checked are used by this connection:" look for 'Client for Microsoft Networks' and 'NetBEUI Protocol'. If these components are not installed, one or more of the following installations may be necessary. Note, the Windows installation disk may be needed as well as administrator security rights.

- a. Installing Client for Microsoft Networks: If Client for Microsoft Networks is not in the list of "The following network components are installed" then, do the following:
 - i. Click the 'Install' button below the list.
 - ii. The Select Network Component Type dialog box will appear.
 - iii. Select 'Client' from the list then click the 'Add' button.
 - iv. Select Microsoft from the Manufacturers list.
 - v. Select 'Client' for Microsoft Networks in the Network Client list.
 - vi. Click 'OK'.
 - b. Installing NetBEUI: If the NetBEUI (with the Ethernet adapter identified on the same line next to it) is not in the list of "The following network components are installed," then do the following:
 - i. Click the 'Install' button below the list.
 - ii. The Select Network Component Type dialog box will appear.
 - iii. Select 'Protocol' and click the 'Add' button.
 - iv. The Select Network Protocol dialog box will appear.
 - v. Select 'NetBEUI' from the Network Protocol list.
 - vi. Click 'OK'.
4. Networking with the *RheoVac DR*: If all of the items above are completed successfully, the UIC or LAN computer should be able to network with the *RheoVac DR*. To search for the *RheoVac DR* from the UIC or LAN computer:
- Open My Computer
 - Each *RheoVac* instrument is identified by a unique network ID. The ID is an "R" plus the first five digits of the serial number found on the unit.
 - Look for the Network ID of your *RheoVac DR*. If the expected Network ID (See previous paragraph) does not show up in the list, then type in the appropriate Address line (\\ "R" plus the first five digits of the serial number) and click the 'Go' button. This may take several seconds and then a RHEOVAC folder will appear, which is the hard drive of the *Rheovac DR*.
 - Open the RHEOVAC folder then open the DATA folder. The *Network ID* \RHEOVAC\DATA folder contains all the stored data. Use Windows copy/paste (COPY - Ctrl C; PASTE- Ctrl V) to save the data files to the UIC or LAN computer.

B.4 Windows® XP

1. Ethernet Cable:
 - UIC Connection: use CAT5 network crossover cable (supplied by Intek) to connect the Ethernet port of the UIC to the Ethernet port on the *RheoVac DR*.
 - LAN Connection: use CAT5 straight high noise-immune Ethernet cable (not supplied)

with RJ45 plug to connect the Ethernet port of the LAN to the Ethernet port of the *RheoVac DR*.

2. Workgroup Identification: Unless otherwise requested, the Workgroup identification for the *RheoVac DR* will be WORKGROUP. To check/set the workgroup name: Click the 'Start' button and select 'Control Panel'. Right click on the 'System' icon and select 'Open'. Select the 'Computer Name' tab. Verify that Workgroup is WORKGROUP. Use the change button to type in a new Workgroup if needed.

3. Check for Installed Network Components: Click the 'Start' button and select 'Control Panel'. Right click on the 'Network Connections' icon and select 'Open'. Or, click the 'Start' button, select 'Connect To', then select 'Show all connections'. Highlight the Local Area Connection that represents the Ethernet adapter. Right click the icon and select 'Properties'. In the new window that pops up, under "This connection uses the following items:", look for Client for Microsoft Networks, NWLink NetBIOS, and NWLink IPX/SPX/NetBios protocols. If these components are not installed, one or more of the following installations may be necessary. Note, the Windows installation disk may be needed as well as administrator security rights.
 - a. Installing Client for Microsoft Networks: If Client for Microsoft Networks is not in the list of "This connection uses the following components:" then, do the following:
 - Click the 'Install' button below the list.
 - The Select Network Component Type dialog box will appear.
 - Select 'Client' from the list then click the 'Add' button.
 - Select 'Microsoft' from the Manufacturers list.
 - Select 'Client for Microsoft Networks' in the Network Client list.
 - Click 'OK'.

 - b. Installing NWLink NetBIOS: If NWLink NetBIOS is not in the list of "This connection uses the following components:" then do the following:
 - Click the 'Install' button below the list.
 - The Select Network Component Type dialog box will appear.
 - Select 'Protocol' and click the 'Add' button.
 - The Select Network Protocol dialog box will appear.
 - Select 'NWLink NetBIOS' from the Network Protocol list.
 - Click 'OK'.

 - c. Installing NWLink IPX/SPX/NetBIOS: If NWLink IPX/SPX/NetBIOS is not in the list of "This connection uses the following components:" then do the following:
 - Click the 'Install' button below the list.
 - The Select Network Component Type dialog box will appear.
 - Select 'Protocol' and click the 'Add' button.
 - The Select Network Protocol dialog box will appear.
 - Select 'NWLink IPX/SPX/NetBIOS' from the Network Protocol list.
 - Click 'OK'.

4. Networking with the *RheoVac DR*: If all of the items above are completed successfully, the UIC or LAN computer should be able to network with the *RheoVac DR*. To search for the *RheoVac 950* from the UIC or LAN computer:
- Open My Computer
 - Each *RheoVac* instrument is identified by a unique network ID. The ID is an “R” plus the first five digits of the serial number found on the unit.
 - Look for the Network ID of your *RheoVac DR*. If the expected Network ID (See previous paragraph) does not show up in the list, then type in the appropriate Address line (\\“R” plus the first five digits of the serial number) and click the ‘Go’ button. This may take several seconds and then a RHEOVAC folder will appear, which is the hard drive of the *RheoVac DR*.
 - Open the *RHEOVAC* folder then open the DATA folder. The *Network ID* \RHEOVAC\DATA folder contains all the stored data. Use Windows copy/paste (COPY - Ctrl C; PASTE- Ctrl V) to save the data files to the UIC or LAN computer.